

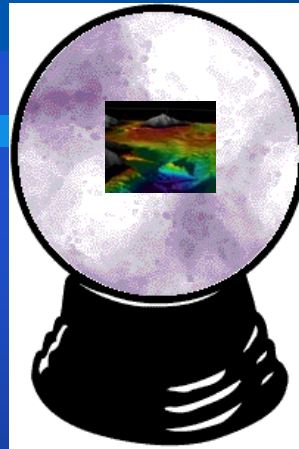

New Frontiers in Seafloor Mapping and Visualization



Larry Mayer
Center for Coastal and Ocean Mapping
NOAA/UNH Joint Hydrographic Center
Univ. of New Hampshire





New Frontiers in Seafloor Mapping

Prediction is very difficult, especially about the future. Niels Bohr

There are many methods for predicting the future. For example, you can read horoscopes, tea leaves, tarot cards, or crystal balls. Collectively, these methods are known as "nutty methods." Or you can put well-researched facts into sophisticated computer models, more commonly referred to as "a complete waste of time."

Scott Adams The Dilbert Future



New Frontiers in Seafloor Mapping

- Focus on acoustic techniques for bathymetry
- Focus on GEBCO domain of deep sea
- Look at near-term trends with some “pie in the sky”





History of Ocean Mapping

Lead Line:

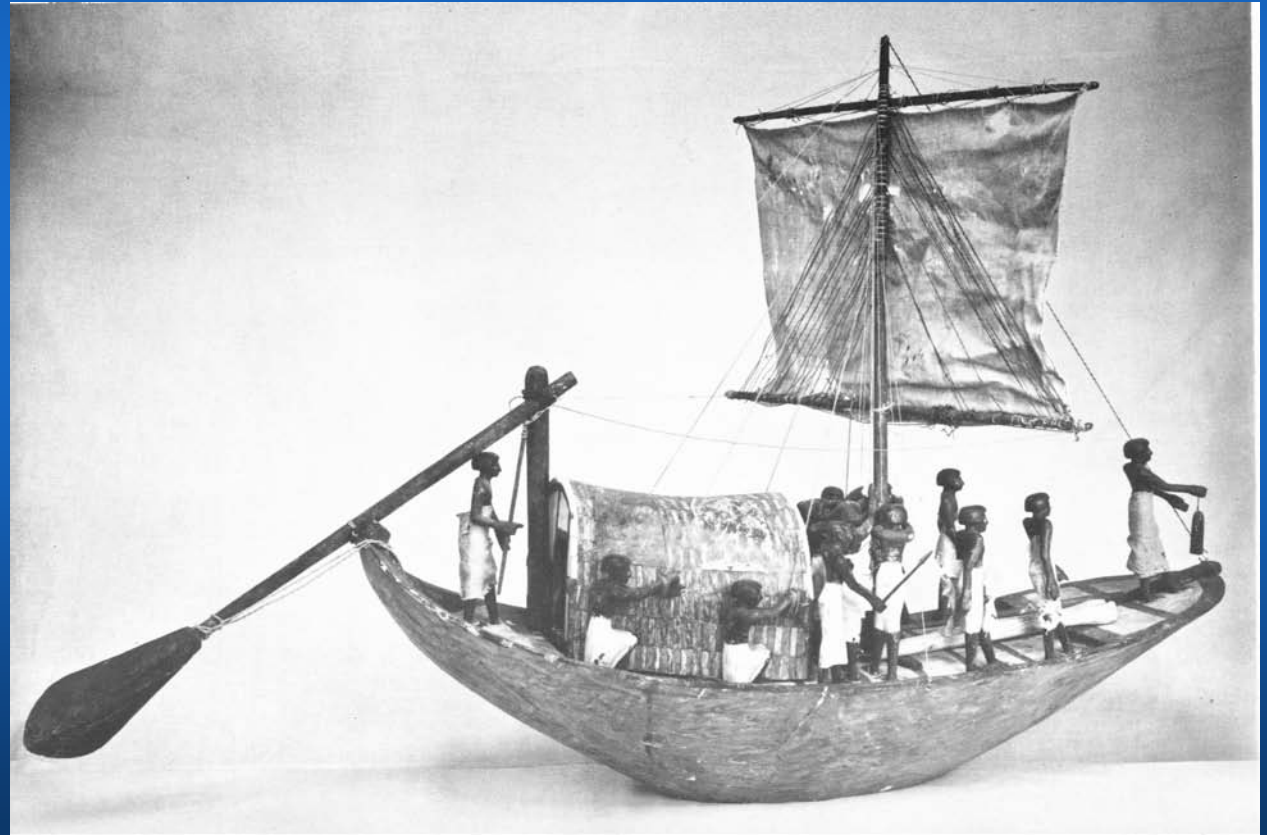

2000 B.C.



The History of Ocean Mapping

Lead Line:

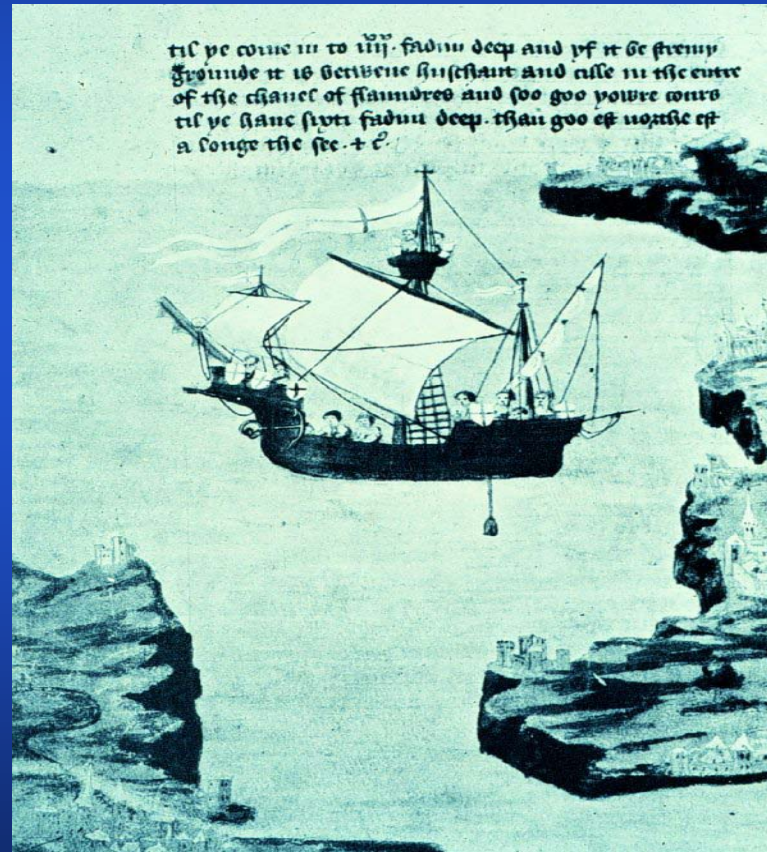

1450



The History of Ocean Mapping

Lead Line:

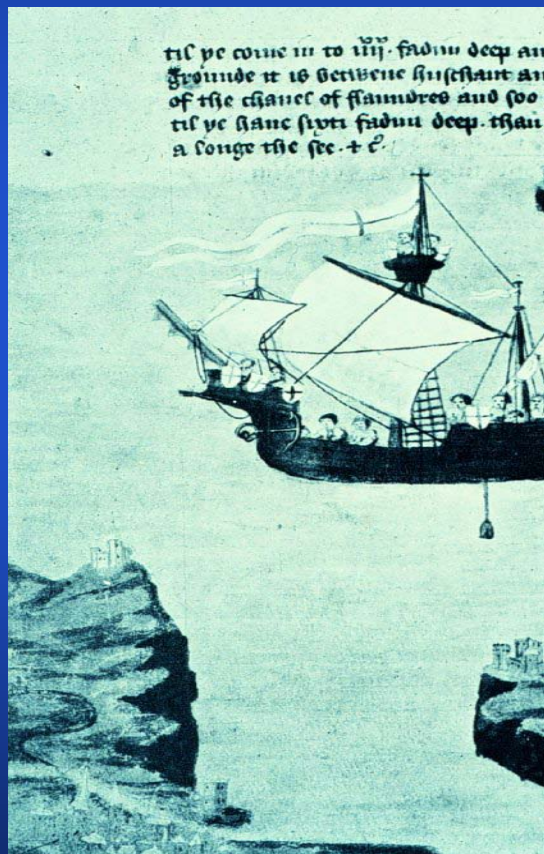

1450



1940



Single Beam Echo Sounder

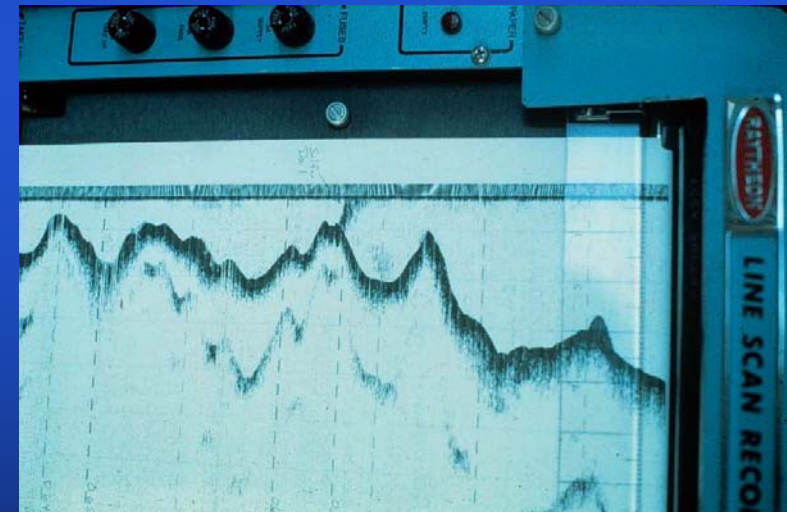
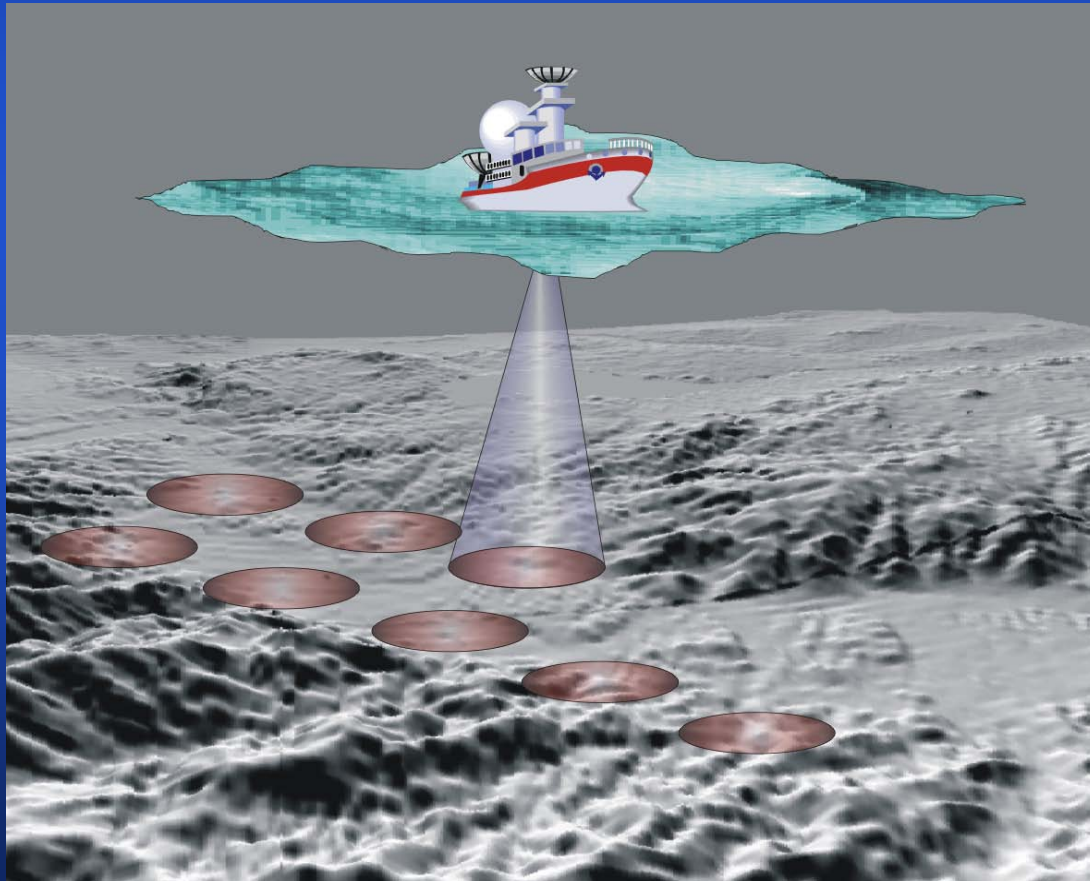

Transmit Beam

Intersection of transmit and receive beams

Receive Beams

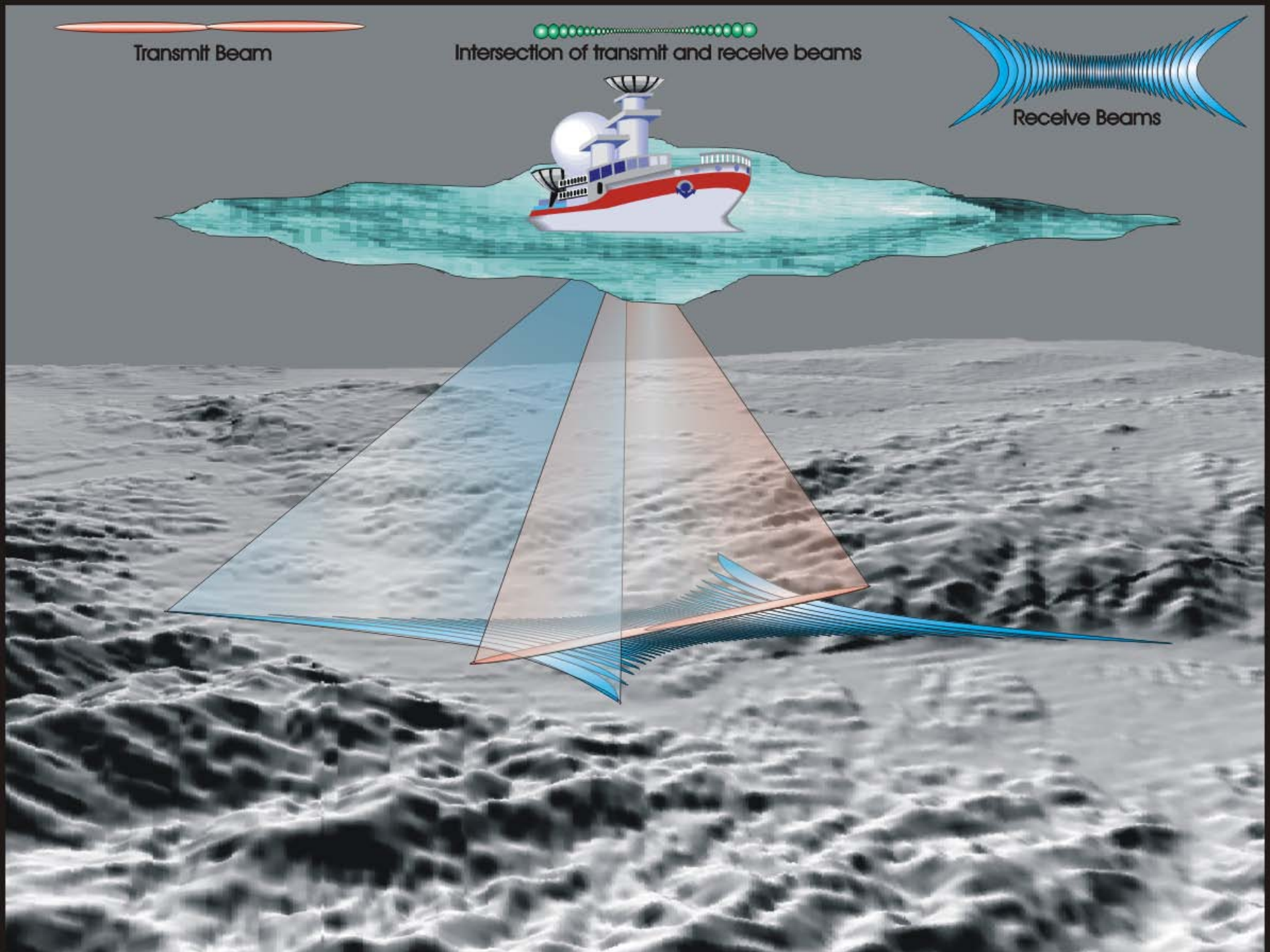

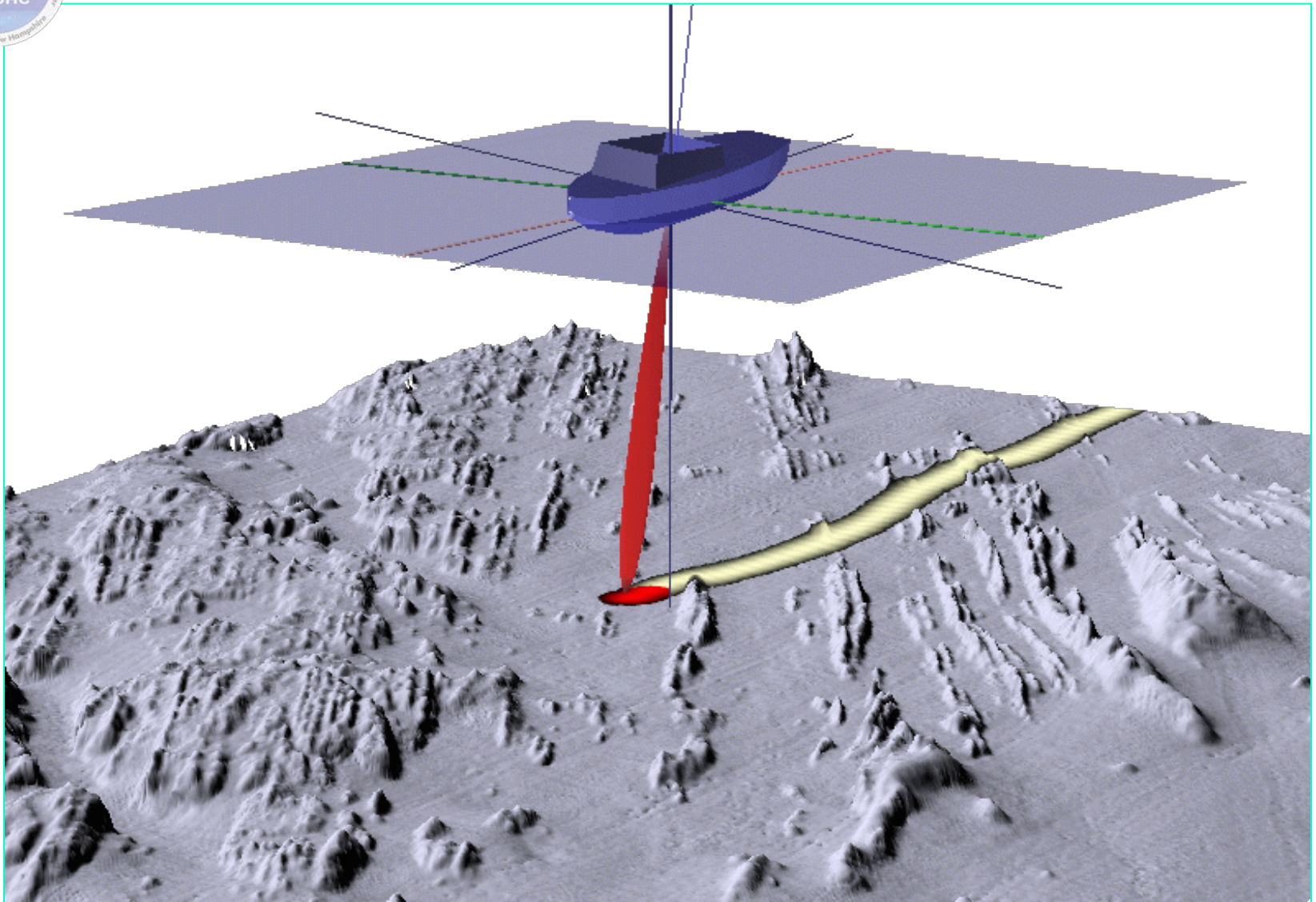

Image derived from theoretical sonar model interacting with artificial seabed DTM using “*SynSwath*”

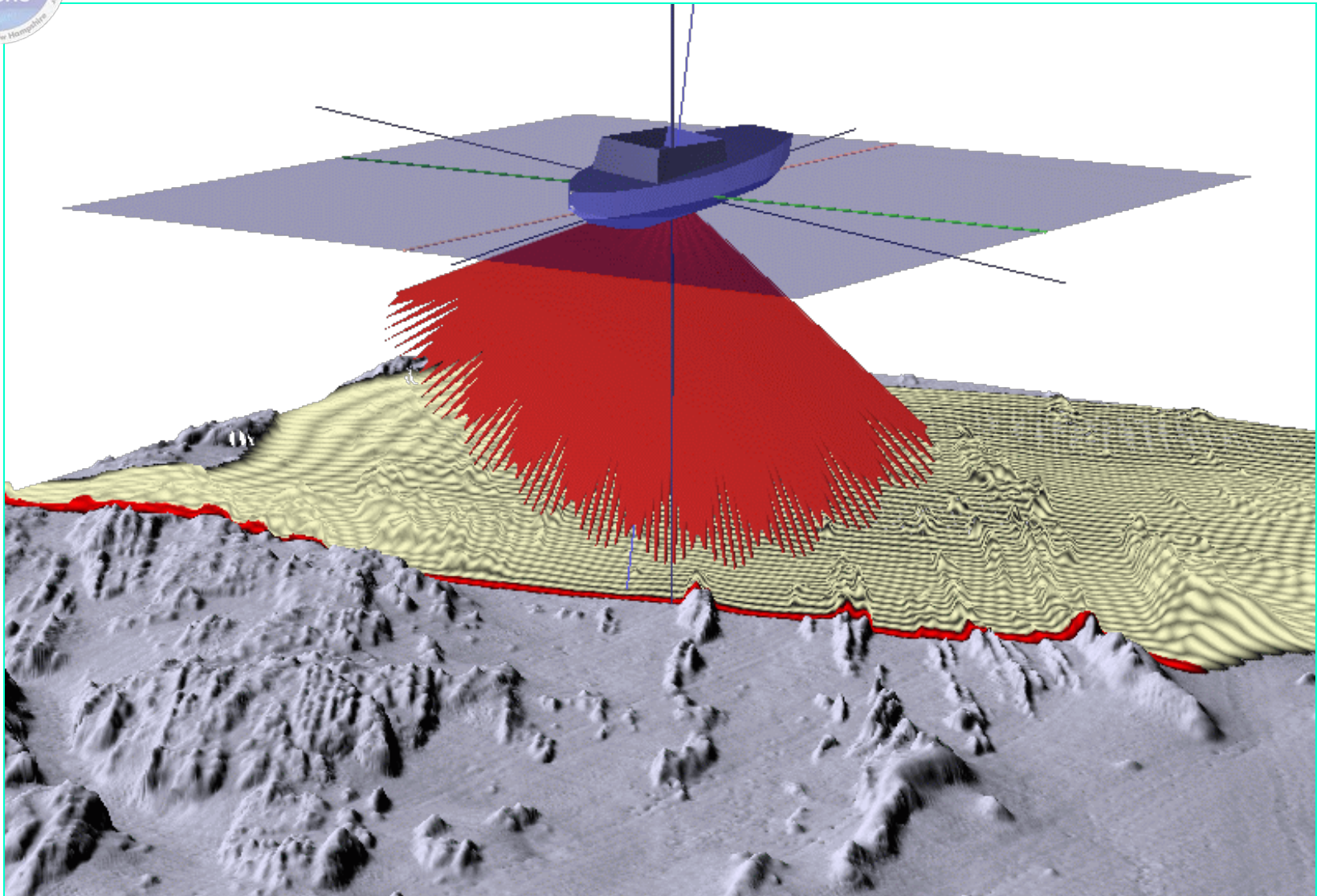
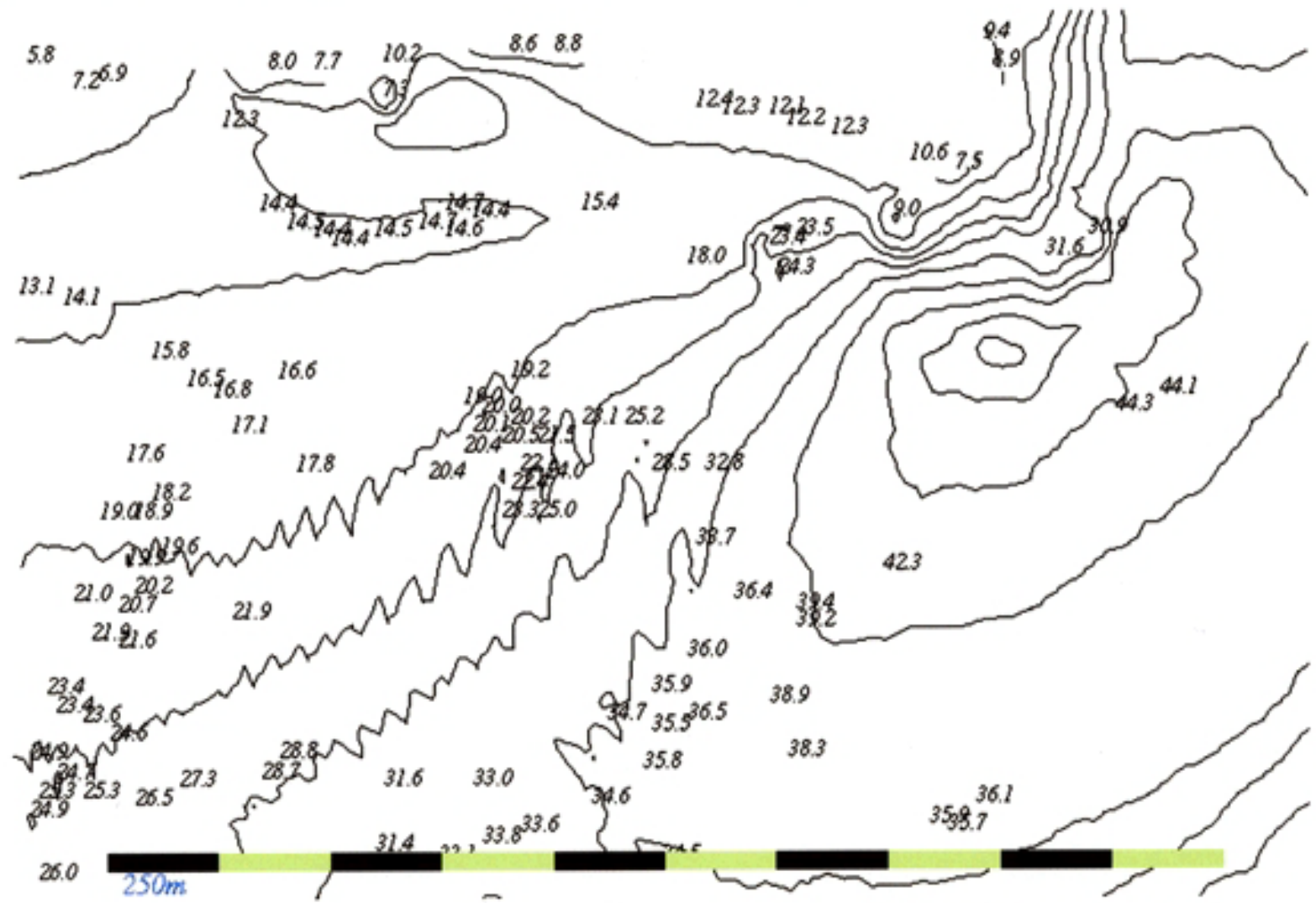

image derived from theoretical sonar model interacting
with artificial seabed DTM using “SynSwath”



C&C Tech., San Francisco Bay: EM1000 8 knots



Processed using **OMG/UNB SwathEd**

Data courtesy of: **USGS(WR) Jim Gardner**

C&C Tech., San Francisco Bay: EM1000 8 knots



Processed using **OMG/UNB SwathEd**

Data courtesy of: **USGS(WR) Jim Gardner**



C&C Tech., San Francisco Bay: EM1000 8 knots



Processed using **OMG/UNB SwathEd**

Data courtesy of: **USGS(WR) Jim Gardner**

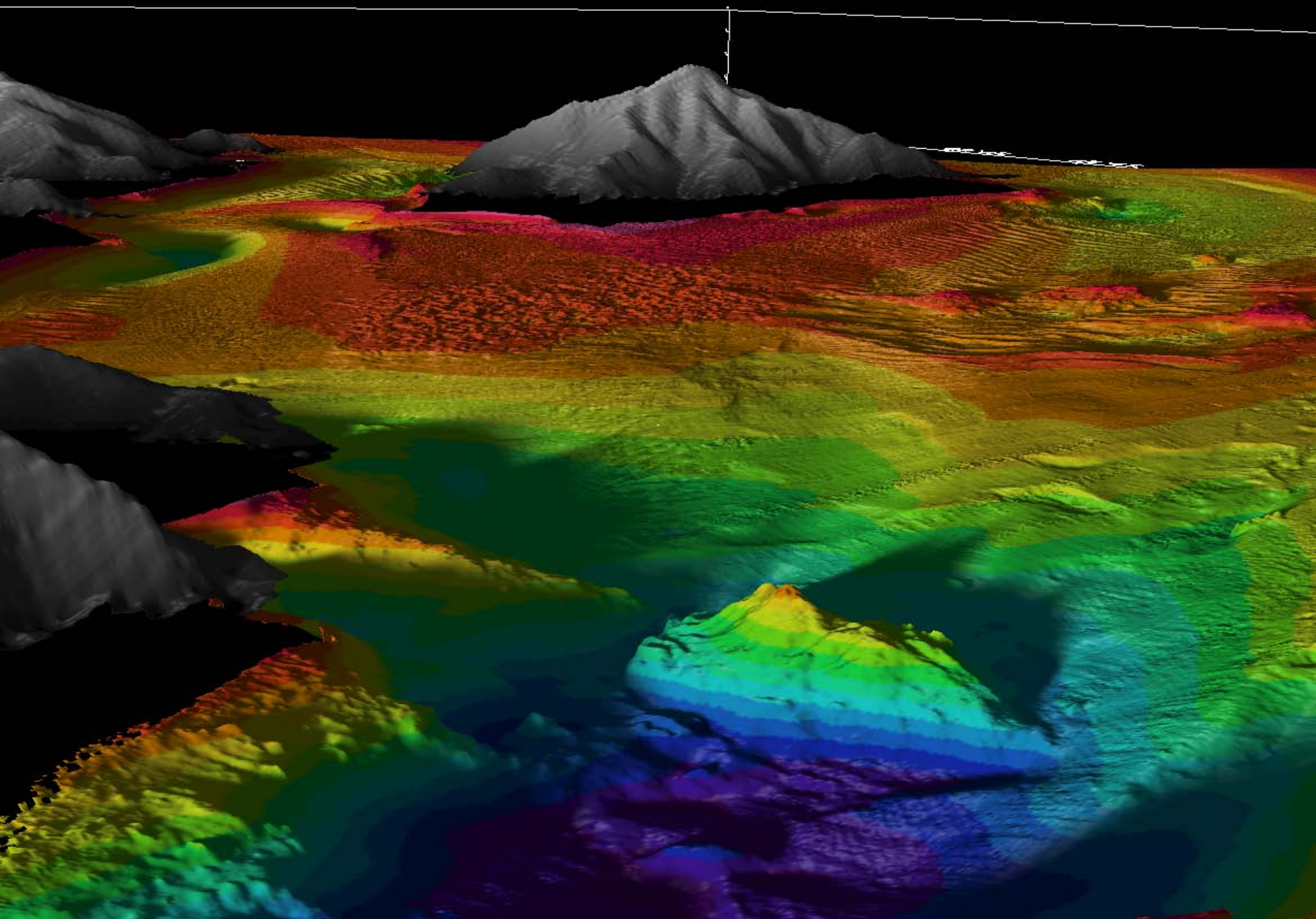

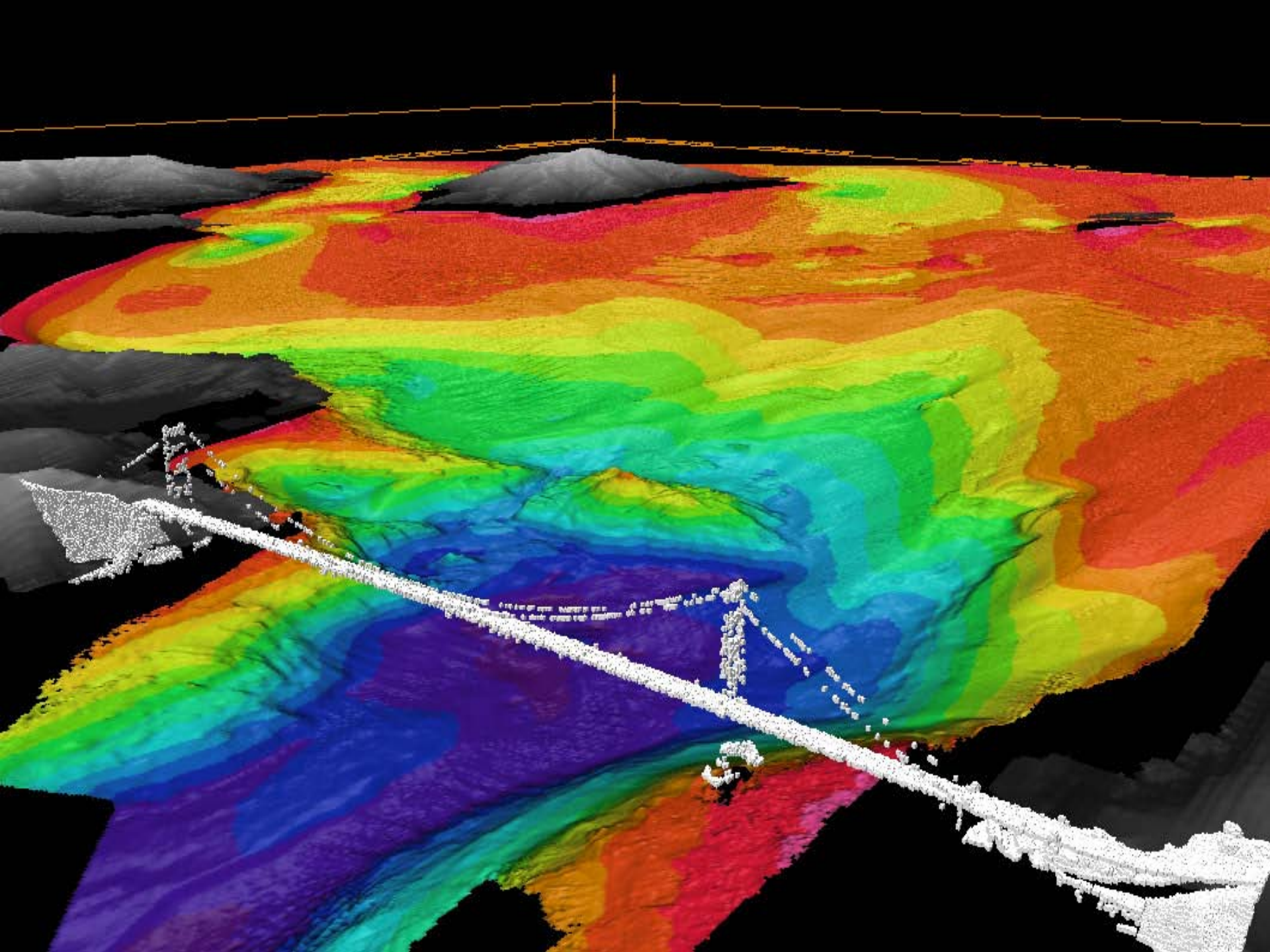

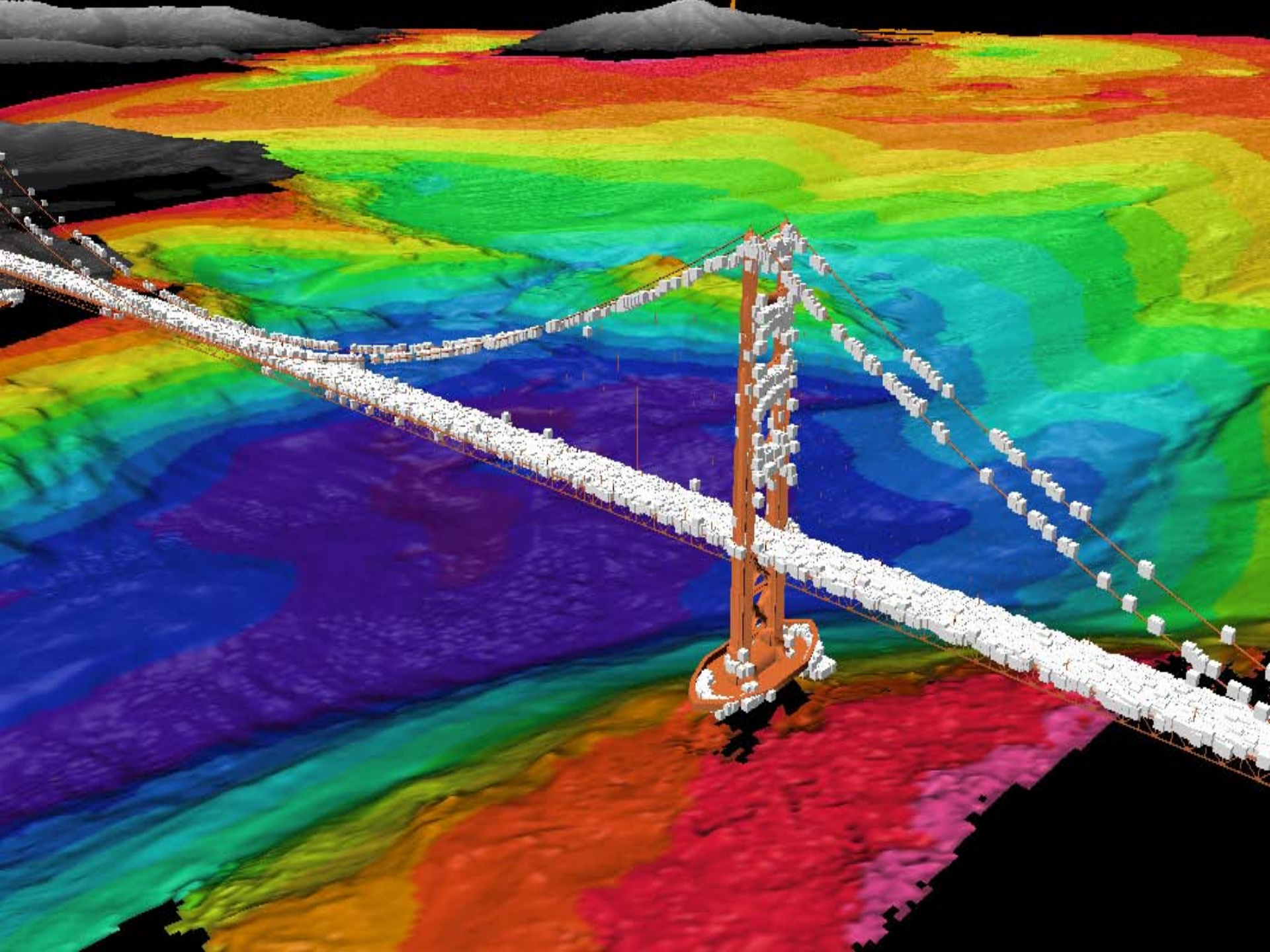

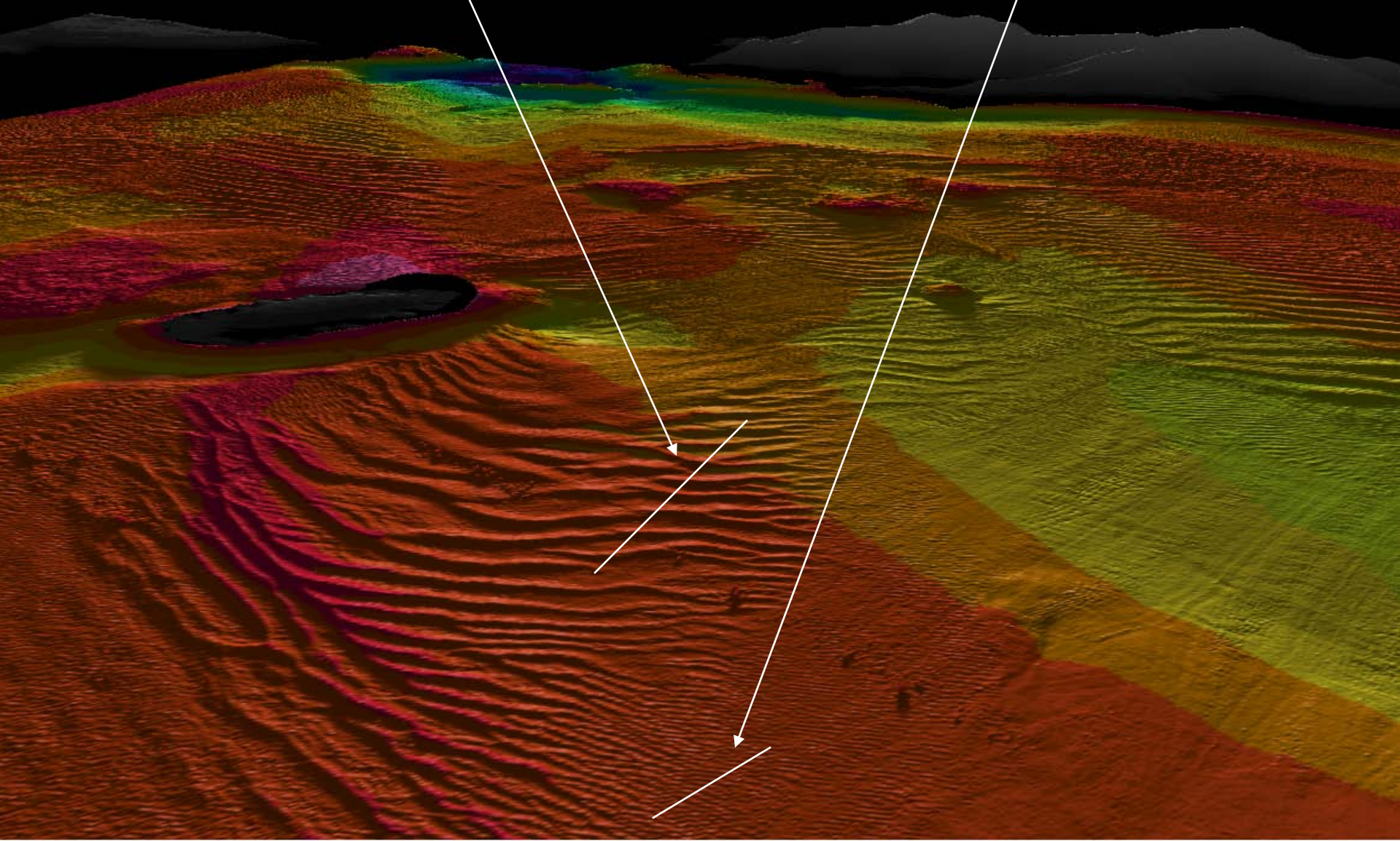
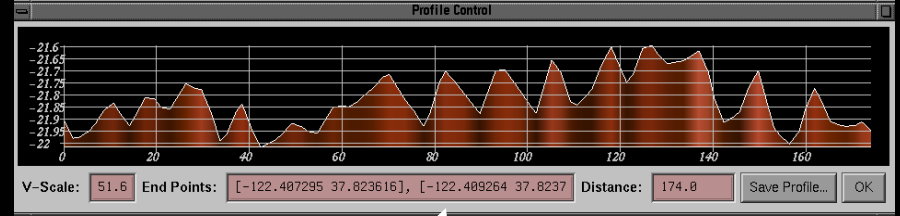
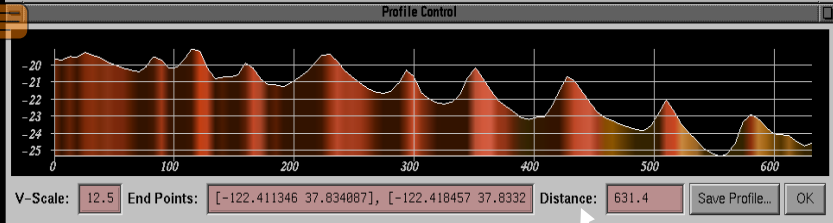



Advances in Offshore Positioning

<u>System</u>	<u>Accuracy</u>
1960's - Sextant	~ 1 n.m. (if good)
1970's - Transit Satellite	~ 100 m intermittently
Early 1990's - GPS	~ 100 m continuously
Late 1990's - DGPS	~ 10 m continuous
Early 00's - RTK	~ 5 cm x,y,z, continuous



Advances in Motion Sensors

1970's - Damped pendulum

1990 - Vertical gyro

1993 - Loose inertial/GPS integration

early 00's - Tightly integrated inertial/GPS

Attitude - .01 deg (RTK)

Heading - .02 deg (RTK or DGPS)

Velocity - .01 m/sec (RTK)

Position - .02 - .10 m (RTK)

200 Hz update rate



Increase in Data Density

in 100 m of water

<i>Method</i>	<i>Soundings/hr</i>	<i>Mb/hr</i>
Lead line	10	.00008
Echo sounder	21,600	.1728
EM-100	292,000	2.1
EM-1000	324,000	27.9 (ss)
EM-3000	1,500,000	79.8 (ss)

in 5 m of water 30,000,000 800 (ss)



CHALLENGES

- **Managing vast amounts of data**
- **Interacting with the data**
- **Presenting large amounts of data**
- **Verifying the data**

**But... the data density opens
up a world of new possibilities**



Advances in Computing Power

Moore's Law

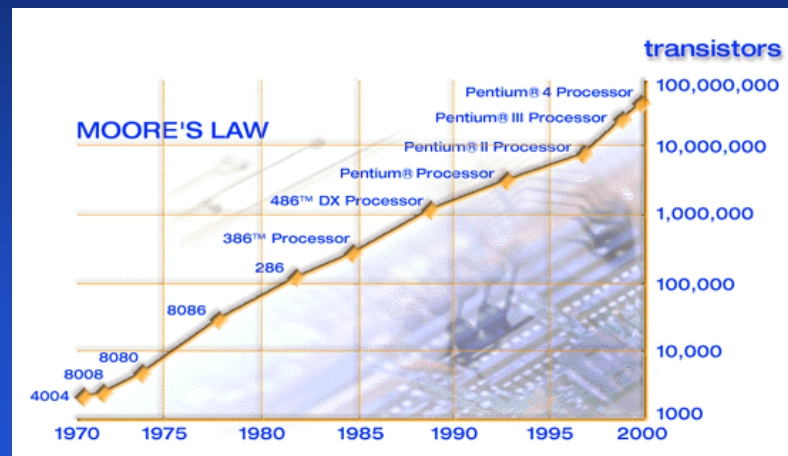

- **30-year trends**

- Speed doubles every 50 months (at least)
- Computer costs cut in half every 32 months
- Memory costs cut in half every 18 months
- Every 10 years computers have become
 - At least 5 times faster
 - Cost 7% of original cost (memory 1%)



Advances in Computing Power

- Time to transfer 1 gigabyte of data:
 - 28.8 kbaud modem 75 hours
 - ISDN 17 hours
 - ADSL 30 minutes
 - 10 BaseT 13 minutes
 - 100 BaseT 80 seconds
 - 1000 BaseT 8 seconds



Benefits of Increased Data Density:

- Redundancy provides increased accuracy**
- Data density allows us to visualize and quantitatively explore the data in new ways**



The seafloor mapping system

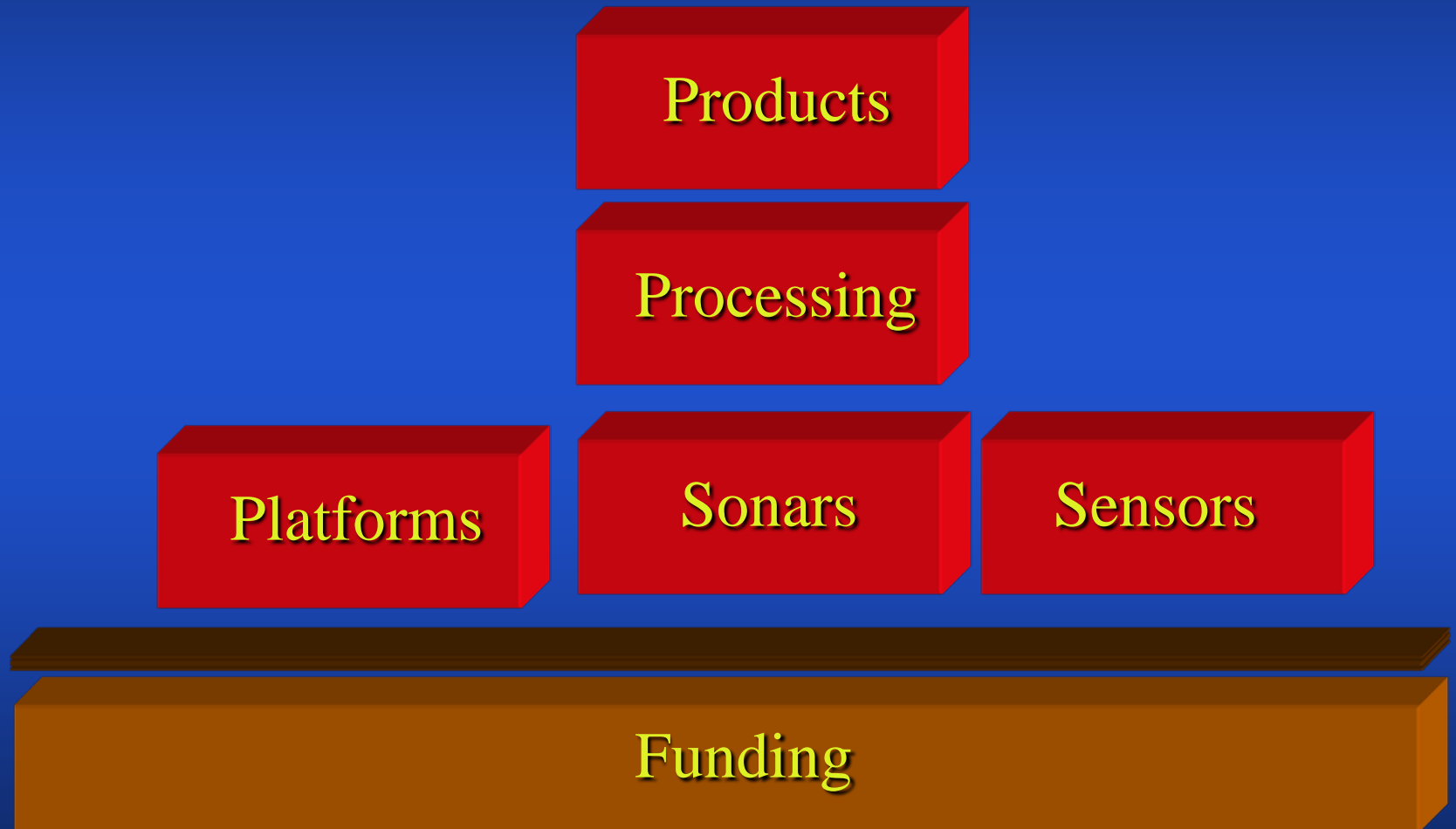



SONARS:



RESON 9001



RESON 8101



RESON 8111



SIMRAD EM100

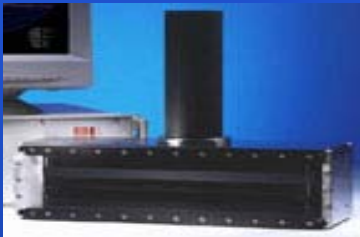

RESON 8125



EM3000



ELAC 1050



SIMRAD EM121



FANSWEEP 20



ISIS100



ODOM ECHOSCAN





Swath-mapping sonars

- *Beam forming sonars:*
 - *bathymetry and co-registered backscatter with angular resolution*
- *Interferometric sonars:*
 - *use phase comparison to generate bathy – sidescan sonar-like imagery*



SONARS:

“Hybrid” sonars: use interferometry for high-quality imagery -- some beam forming for ambiguity resolution

Trends: better algorithms for interferometric solutions = higher resolution bathymetry while maintaining high-quality, co-registered imagery and wide swath – also SAS



FanSweep 20



SONARS:

“Focused” sonars: compensate for wavefront curvature to allow focusing in the near-field. Much higher target resolution

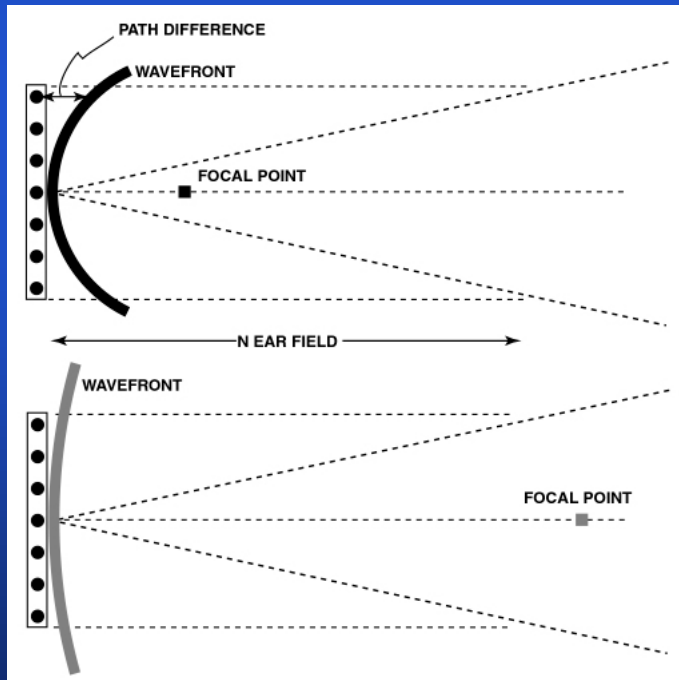

5m range

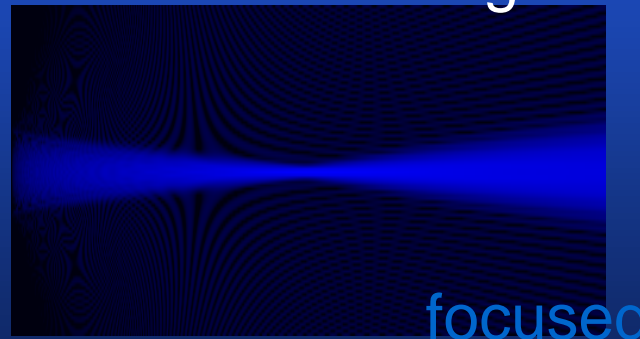

SEABAT 8125



Focused Sonar

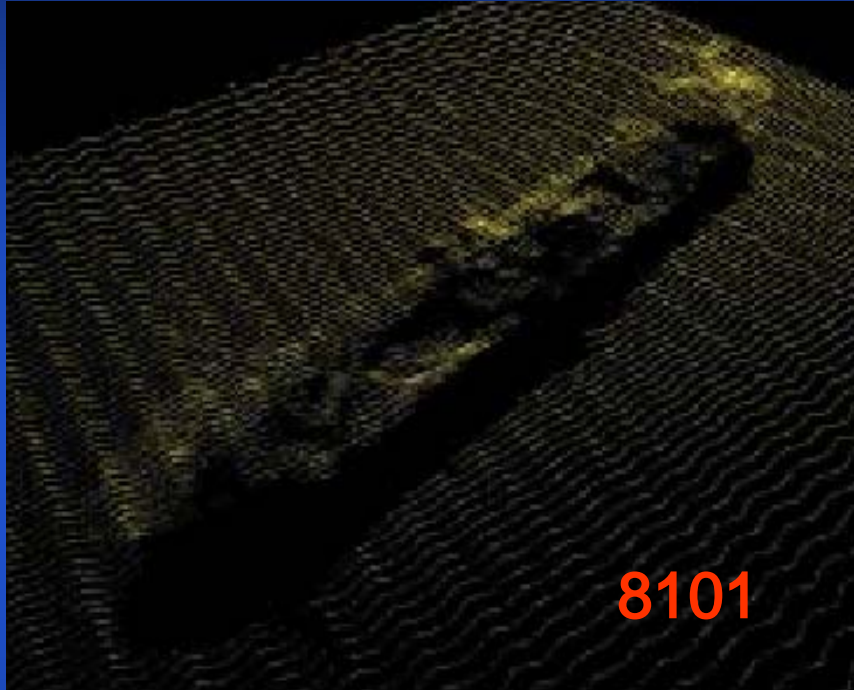

unfocused

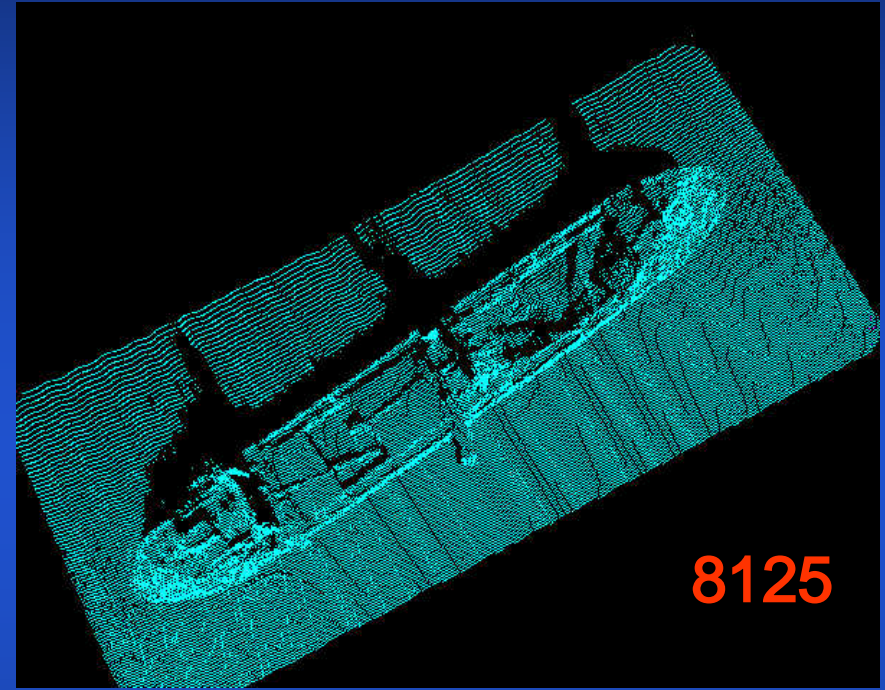

focused

SeaBat 8125 and 8101 bathymetry collected at 5 knots over the 103m long freighter, Al-Mansoura, in 50 m of water in the Persian Gulf after hitting a platform at night in 1985. (Courtesy of RESON)



SCUTTLED GERMAN FLEET IN SCAPA FLOW

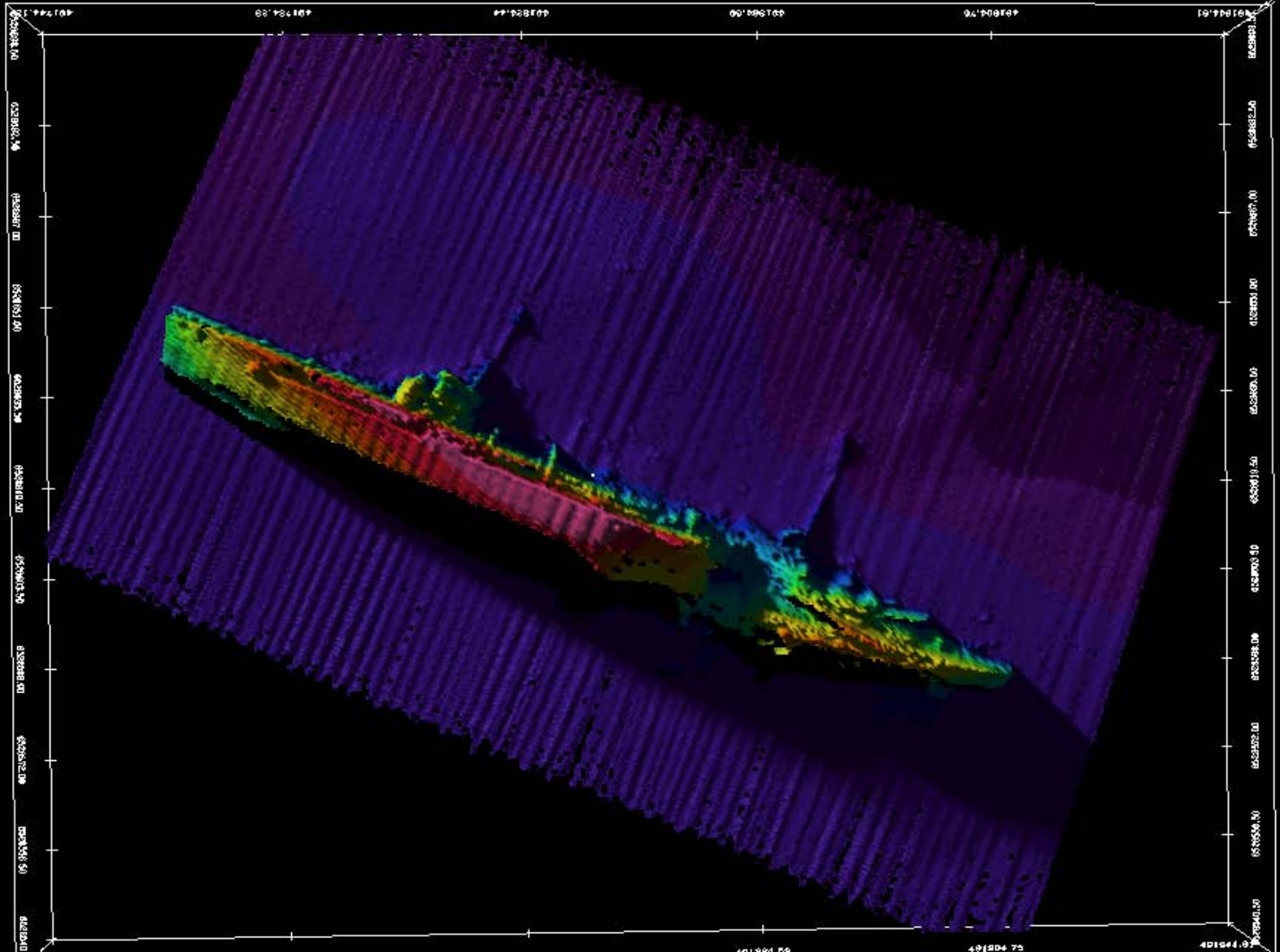



Mulberry Harbor off Omaha Beach

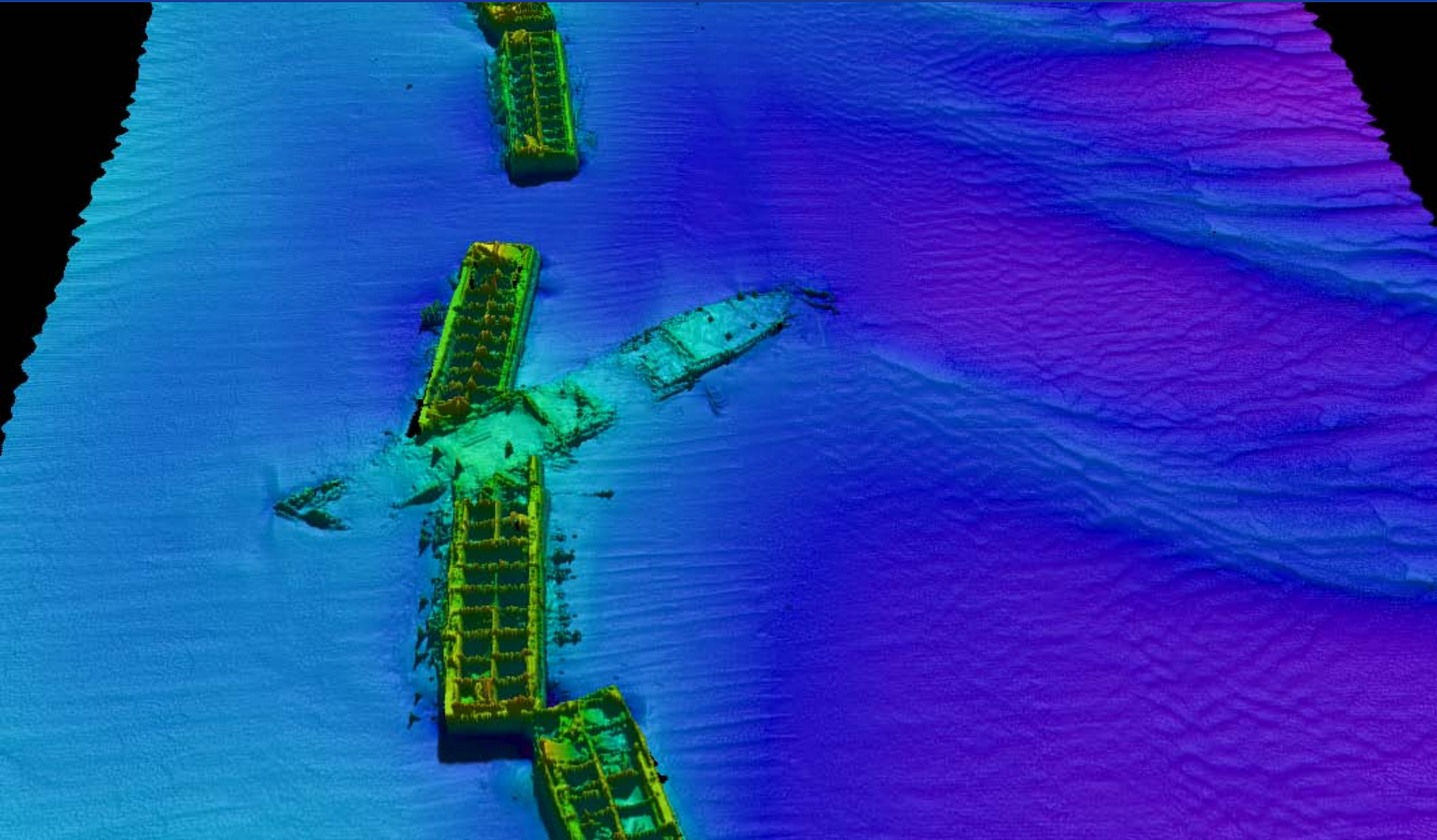



Sherman 'DD' Tank off Omaha Beach

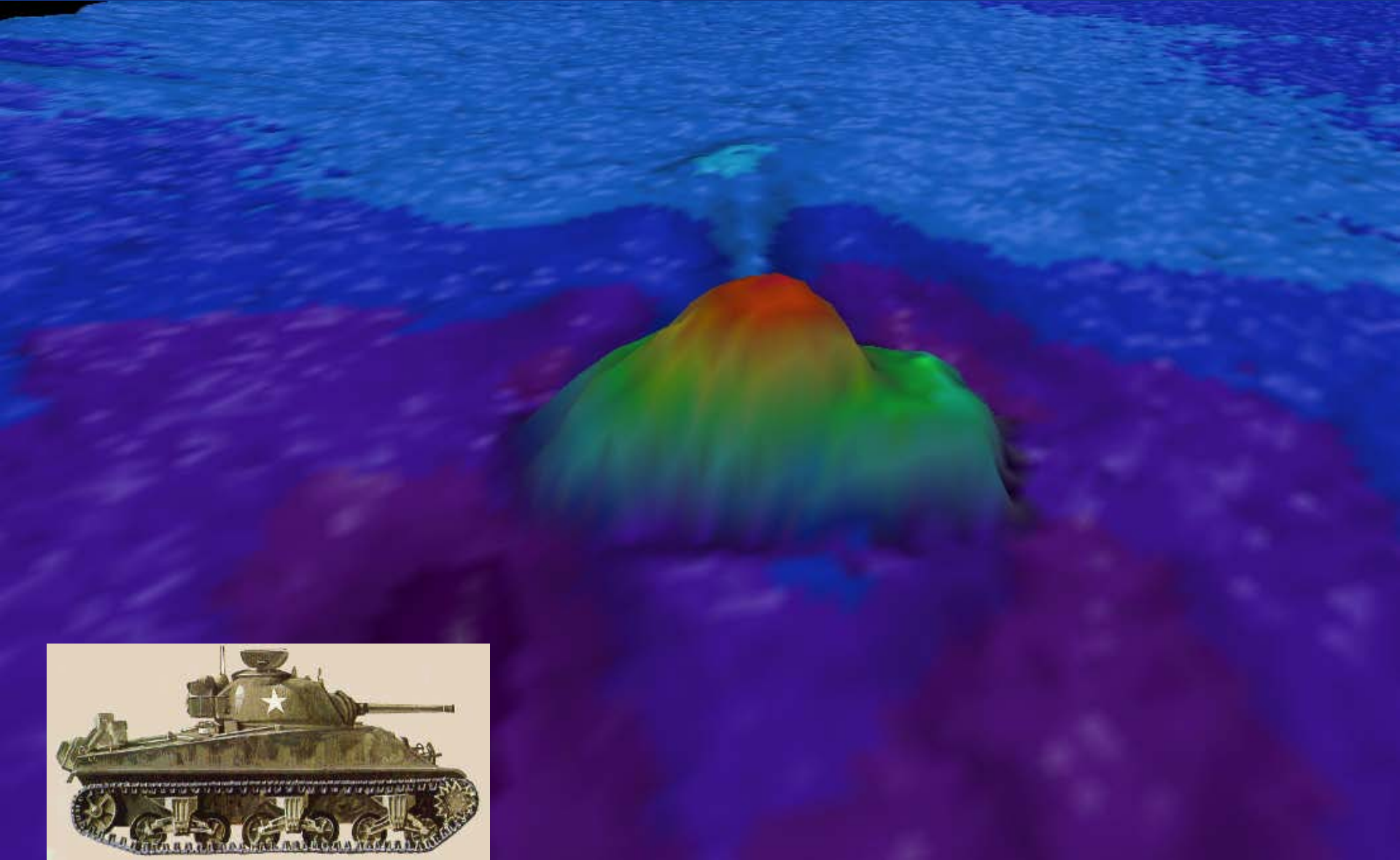

0 selected

record=378377
subrecord=1

line=Line 0 (0)
file=C:\PFM_FILES\NORMANDY_PFM\Normandy\Tanks_UTM_025_line21 (0)

(658060.82, 5474079.96, -18.24)
(0°49'17.3", 49°23'55.9", -18.24)

Sherman 'DD' Tank off Omaha Beach

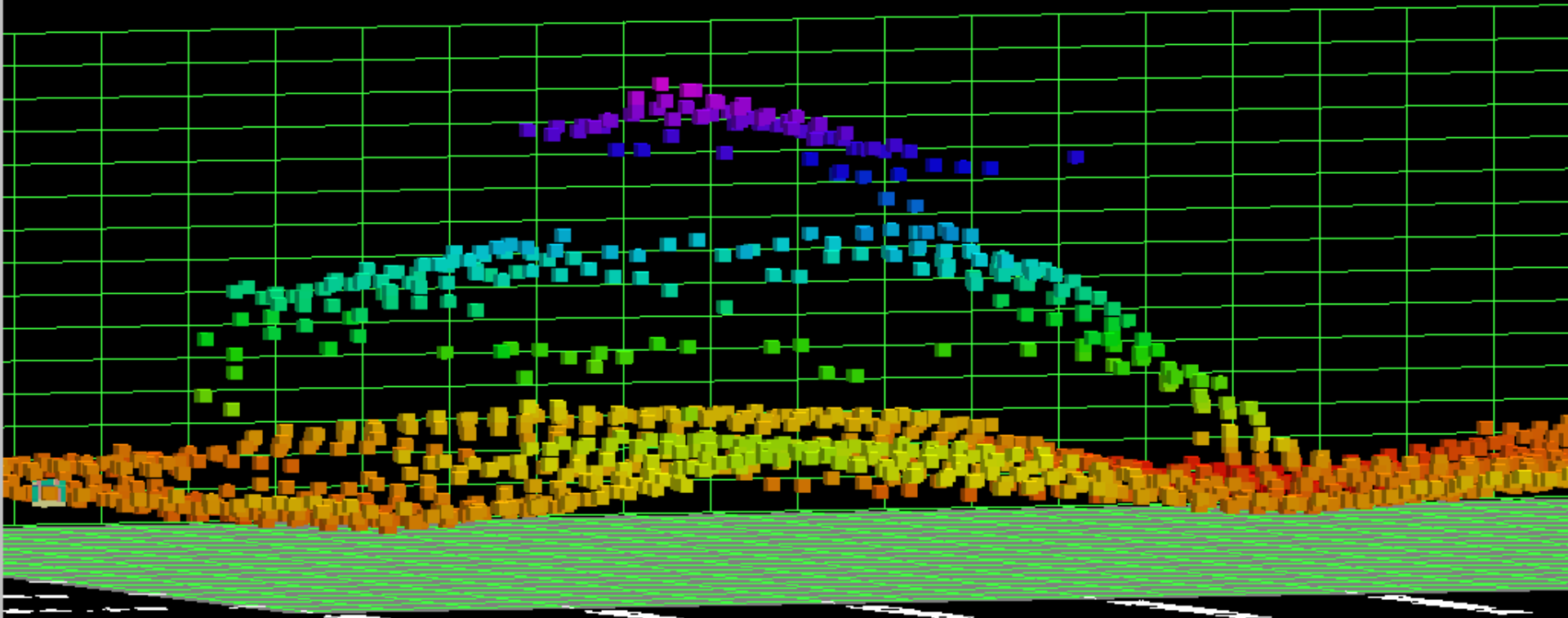



Martha's Vineyard Mine Burial Site

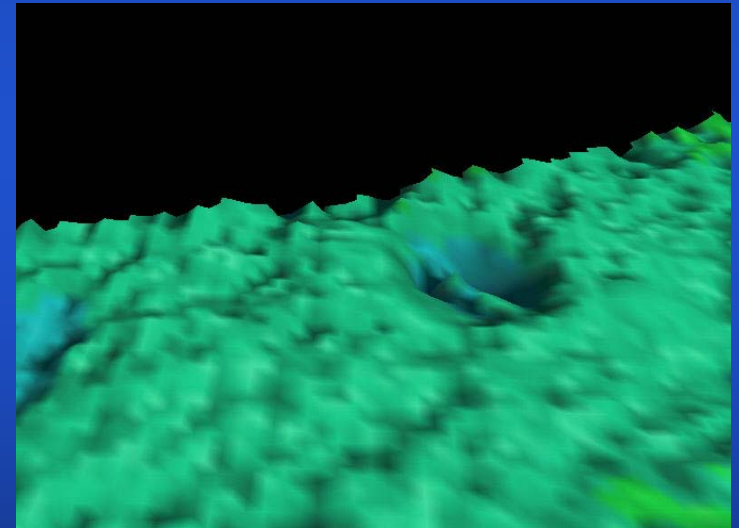
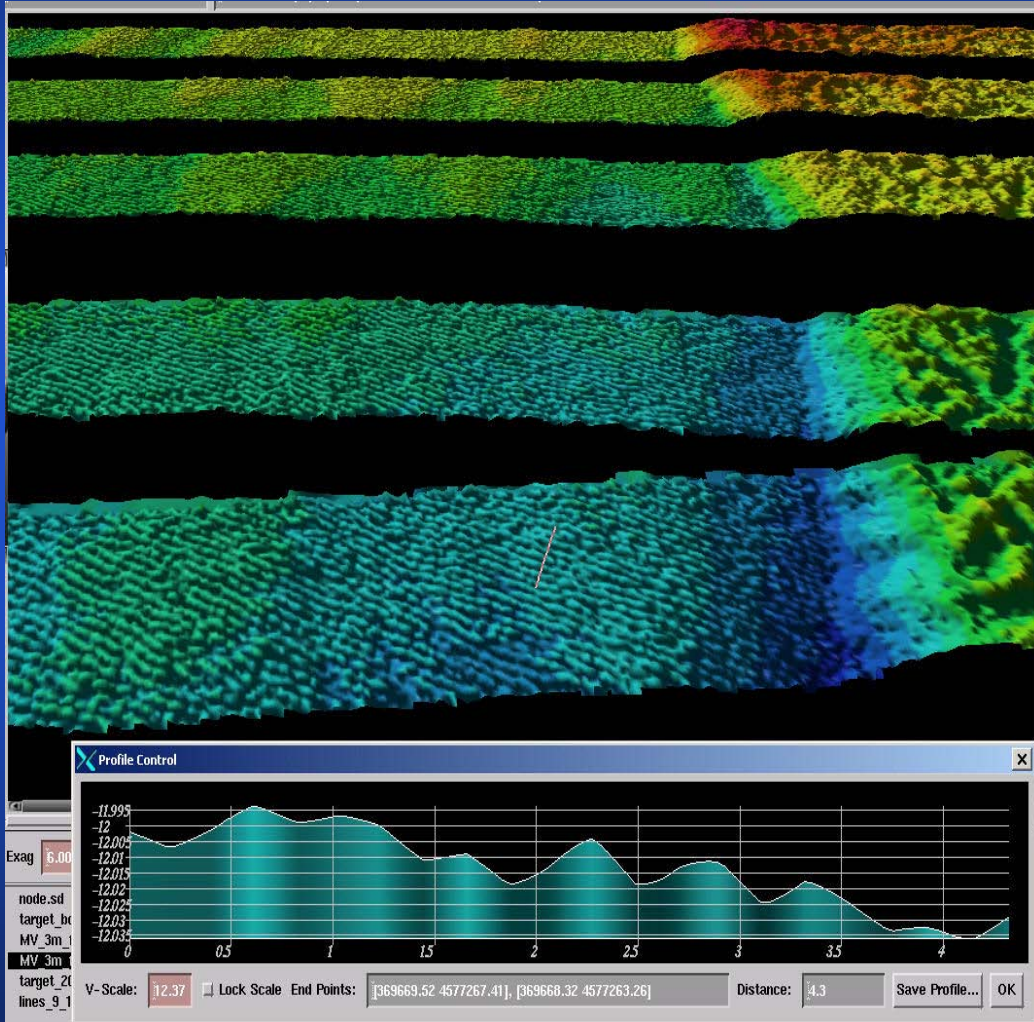



SONARS:

“CHIRP” multibeam sonars:

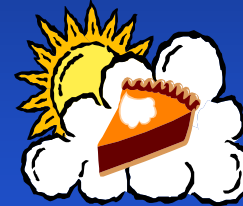

- Increased bandwidth = increased temporal resolution
- Increased bandwidth = multiple pings in water = increased sounding density
- Increased bandwidth = “multispectral” thematic mapping



The Beauty of Bandwidth

Radarsat

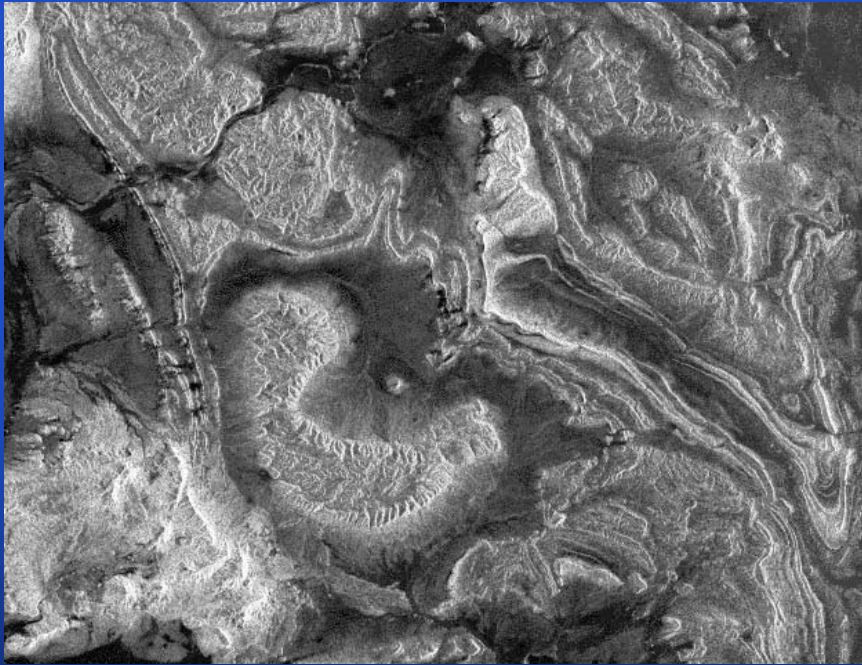

Narrow band



Full bandwidth

New Transducer Materials:

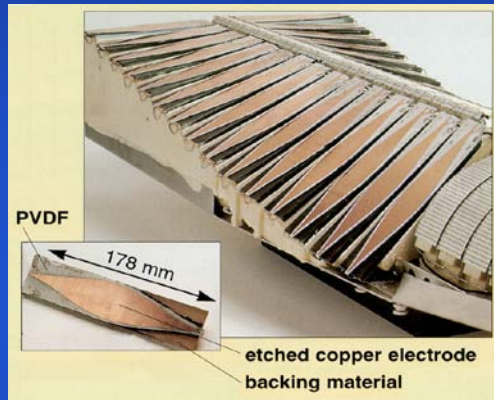

PVDF polyvinylidene fluoride
(Airmar Corp)

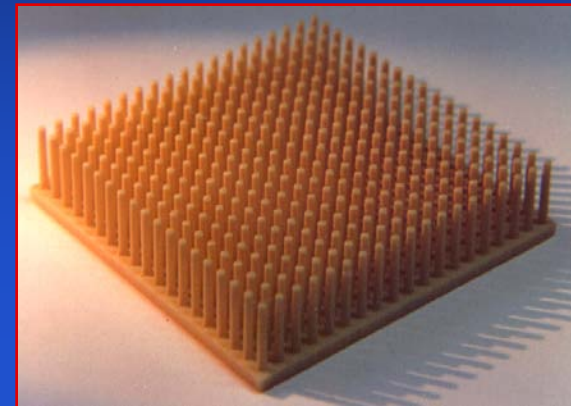

1-3 Piezocomposite
(Materials Systems Inc)

cymbals

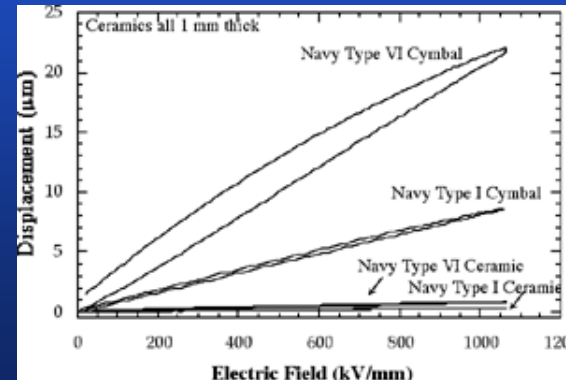
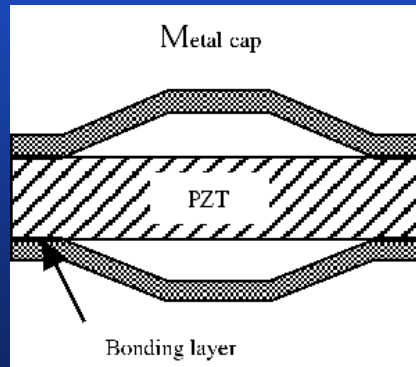



Mapping the water column:

SM2000

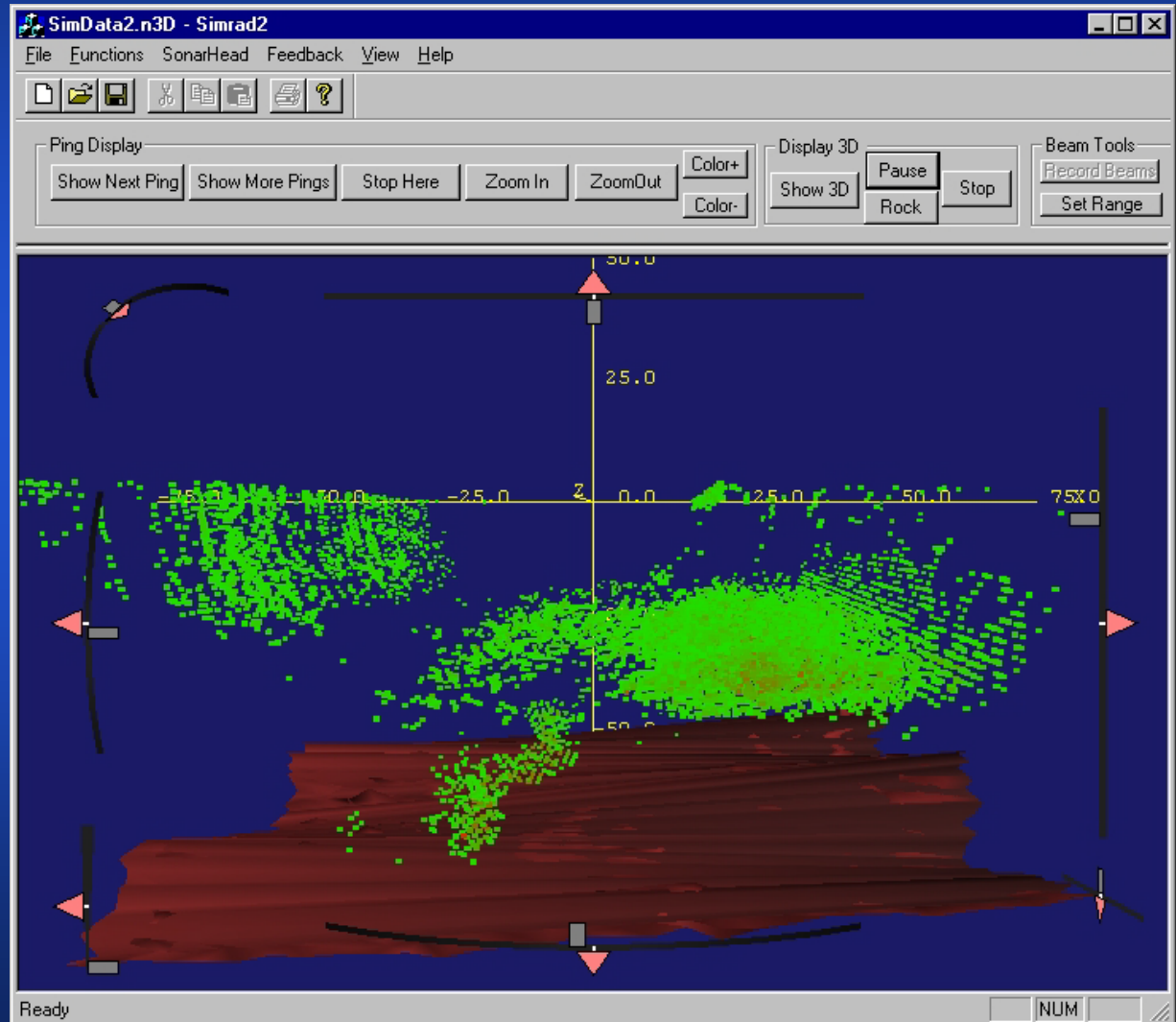



Midwater target mapping

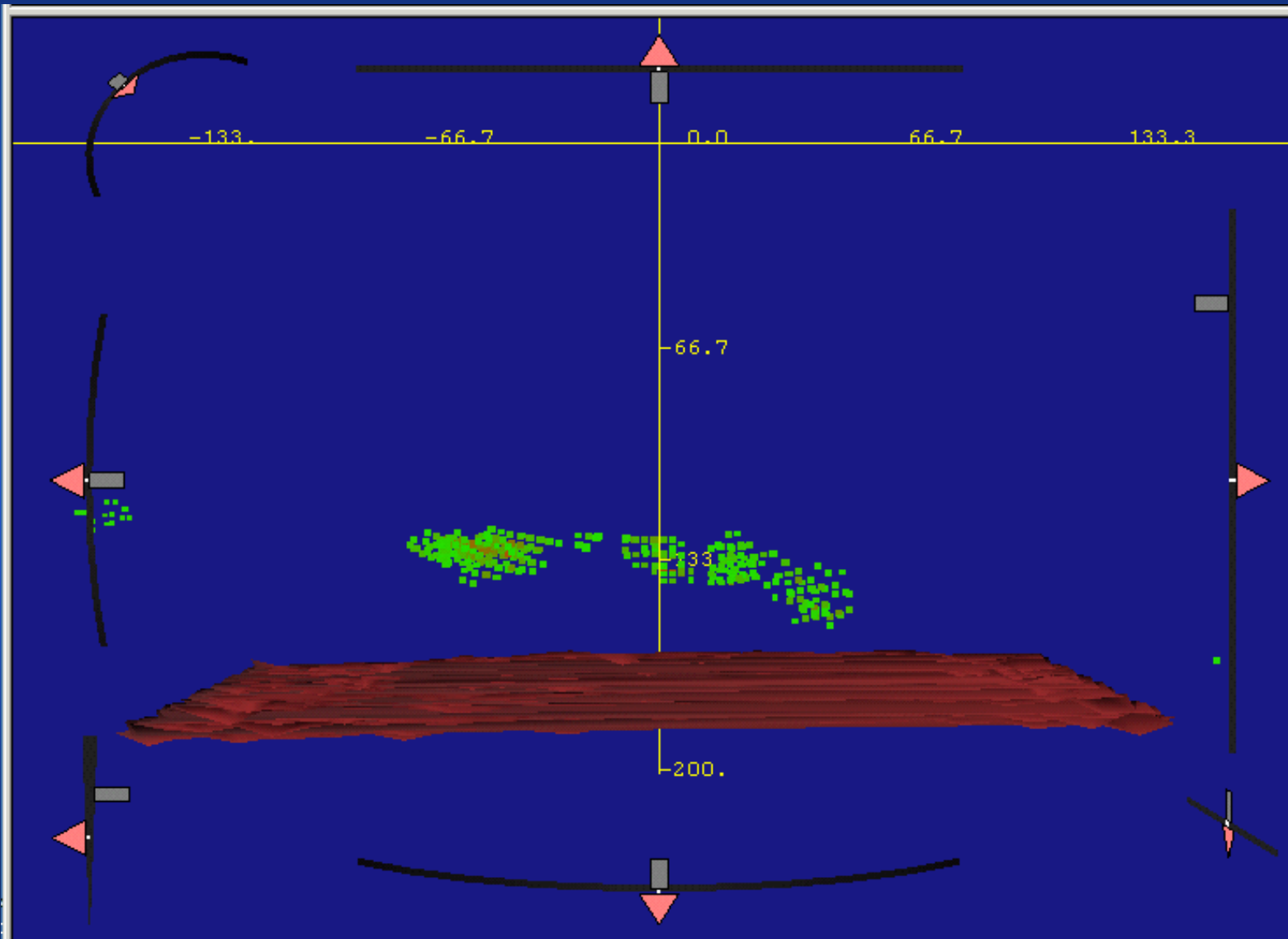



SENSORS:

Motion Sensors:

Tightly integrated inertial/GPS

Attitude - .01 deg (RTK)

Heading - .02 deg (RTK or DGPS)

Velocity - .01 m/sec (RTK)

Position - .02 - .10 m (RTK)

200 Hz update rate

Continued improvements - not limiting factor



SENSORS:

Sound Speed Profile:

Still biggest source of error

- Improved MVP and other continuously profiling sensors



- Tomographic arrays

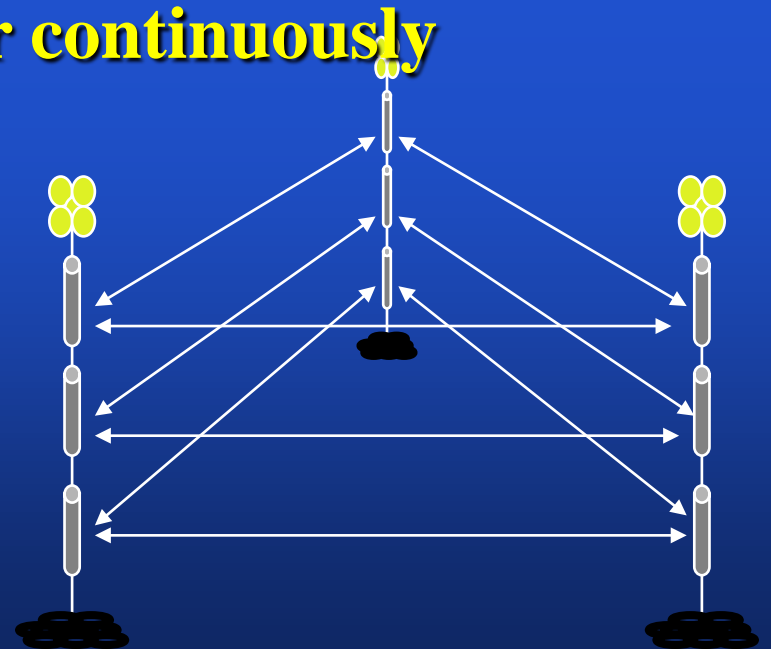



Moving Vessel Profiler

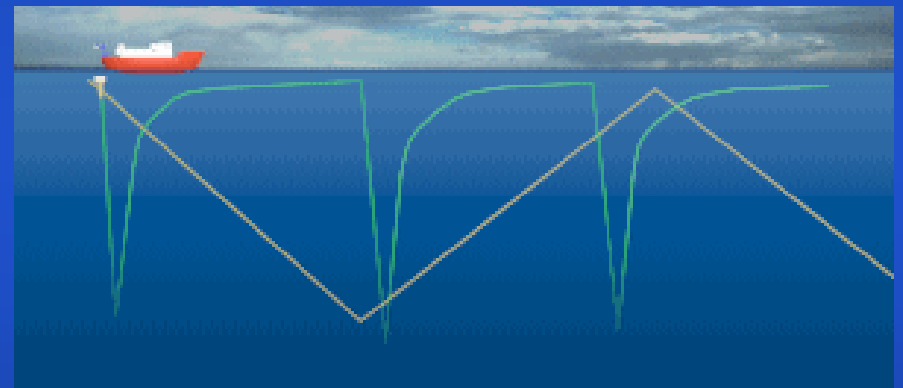
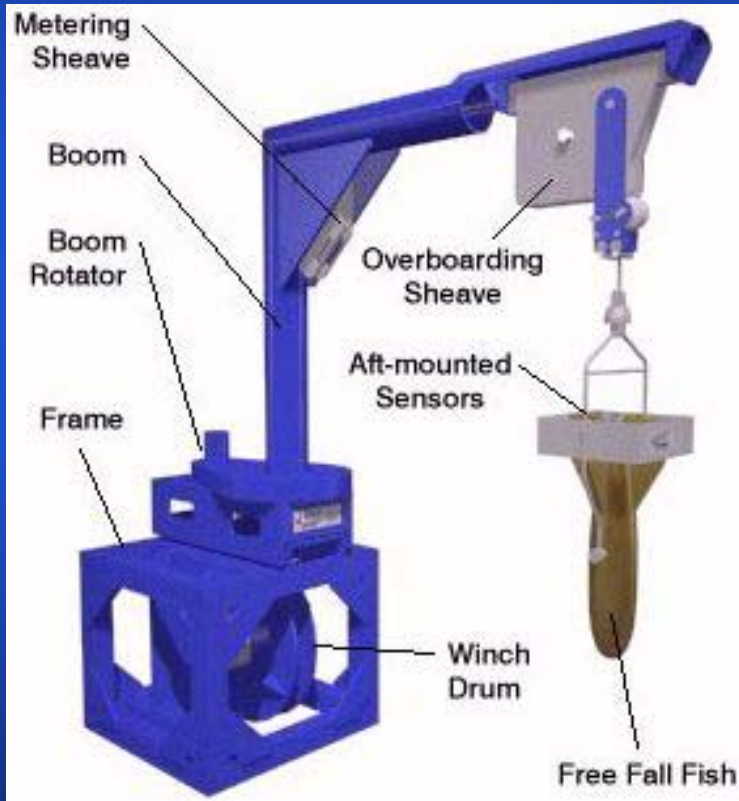



Instrumented Tow Cable



Sampled temperature data collected from South of New England using the LBVDS Instrumented Tow Cable in June 2000.

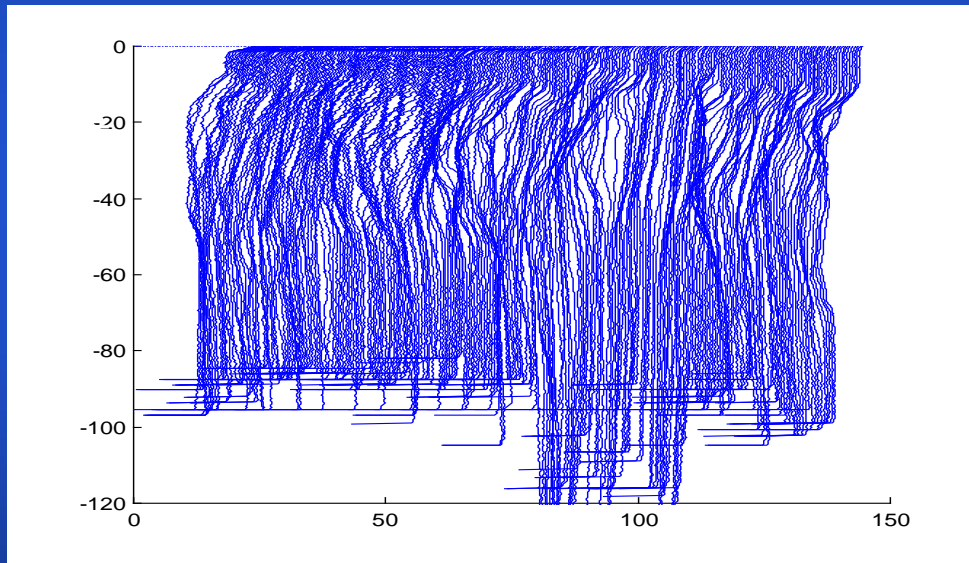

Temperature Profiles every 2 minutes over 12 hours
Units: Degrees C (offset by time in minutes since comex)

Sampled temperature data collected from South of New England using the Instrumented Tow Cable in June 2000

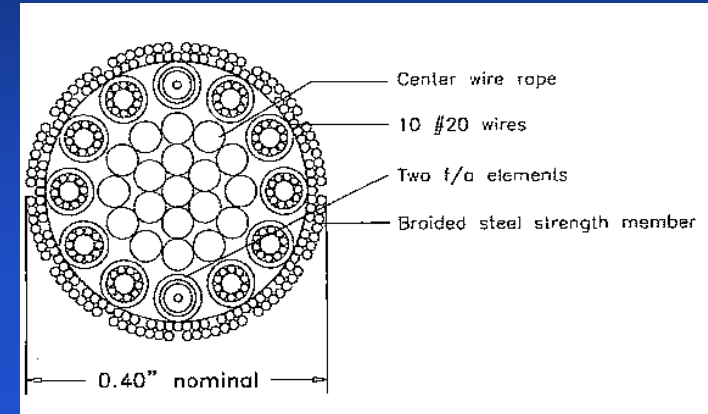

● Cable Characteristics

- Unfaired 0.40" Diameter Steel Cable
- Weight in Air = 0.22 lb/ft
- Total Length = 6000 ft
- Winch: 54" width; 48" height; 38" depth; 1000 kg
- Achievable Depth = 400 ft at 16 knots
- Survival Speed = 30 Knots
- Depth and Temperature Sensor at bottom



PLATFORMS:

The future of deepwater mapping is
SHALLOW WATER MAPPING



Hugin AUV



PLATFORMS:

ROV's and particularly AUV's:

- **HIGH RESOLUTION BATHYMETRY**

Example - 2000m Depth:

Surface Ship - 7.0m Depth Resolution

AUV - 0.2m Depth Resolution

- **HIGH RESOLUTION CO-LOCATED IMAGERY**

Example - 2000m Depth:

Surface Ship - 40.0m pixel

AUV - 0.5m pixel

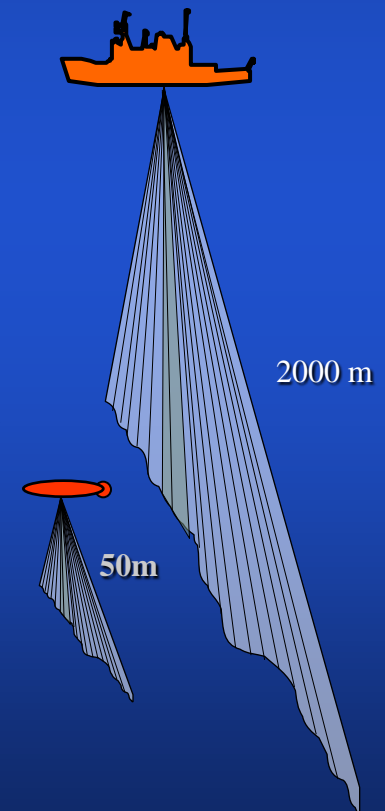



NESTED SURVEYS:

Satellite, Multibeam, Deep Tow, ROV,
Submersible

- an example from ROPOS -- poor man's multibeam - IMAGENIX sector scanner



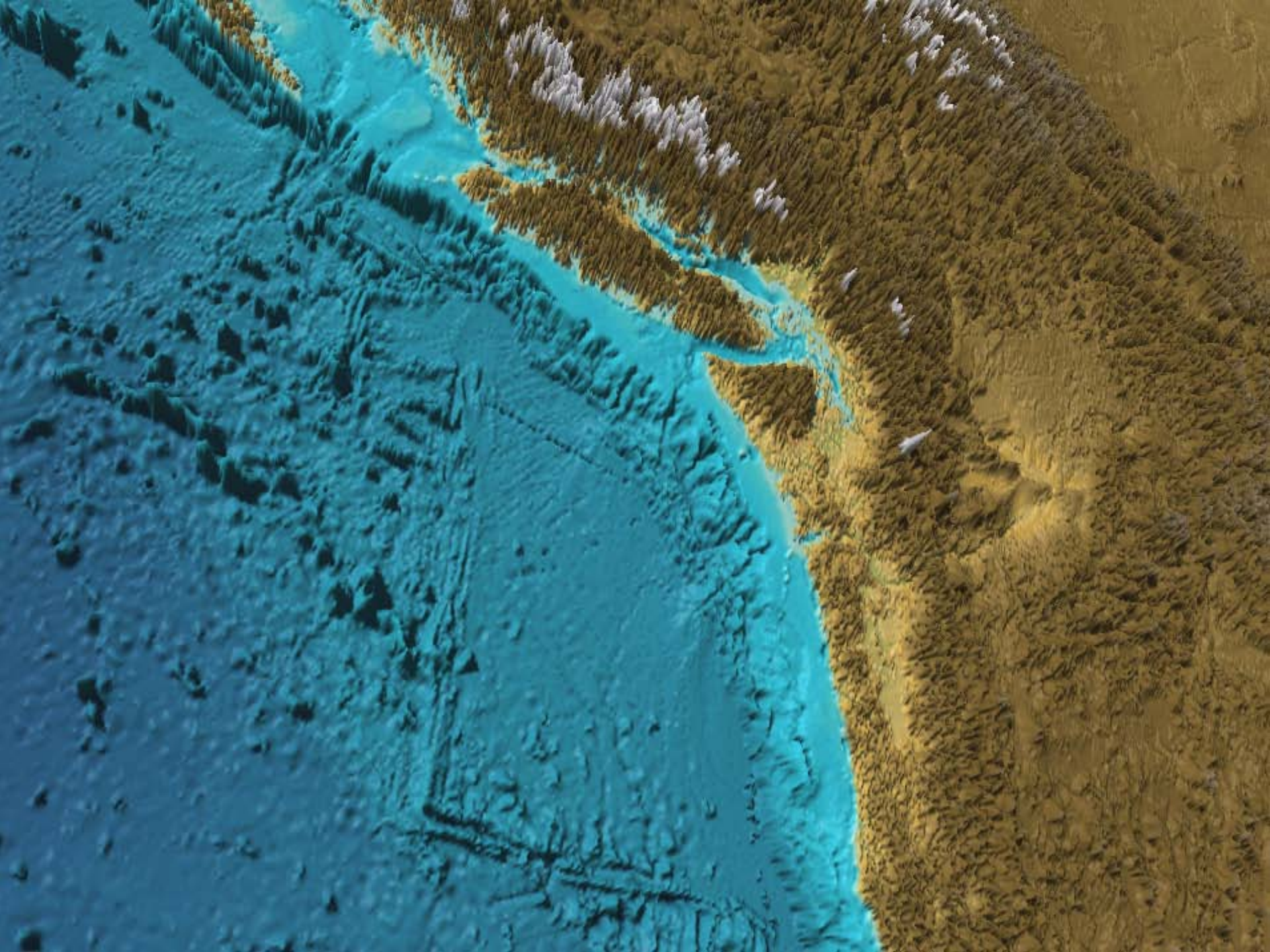

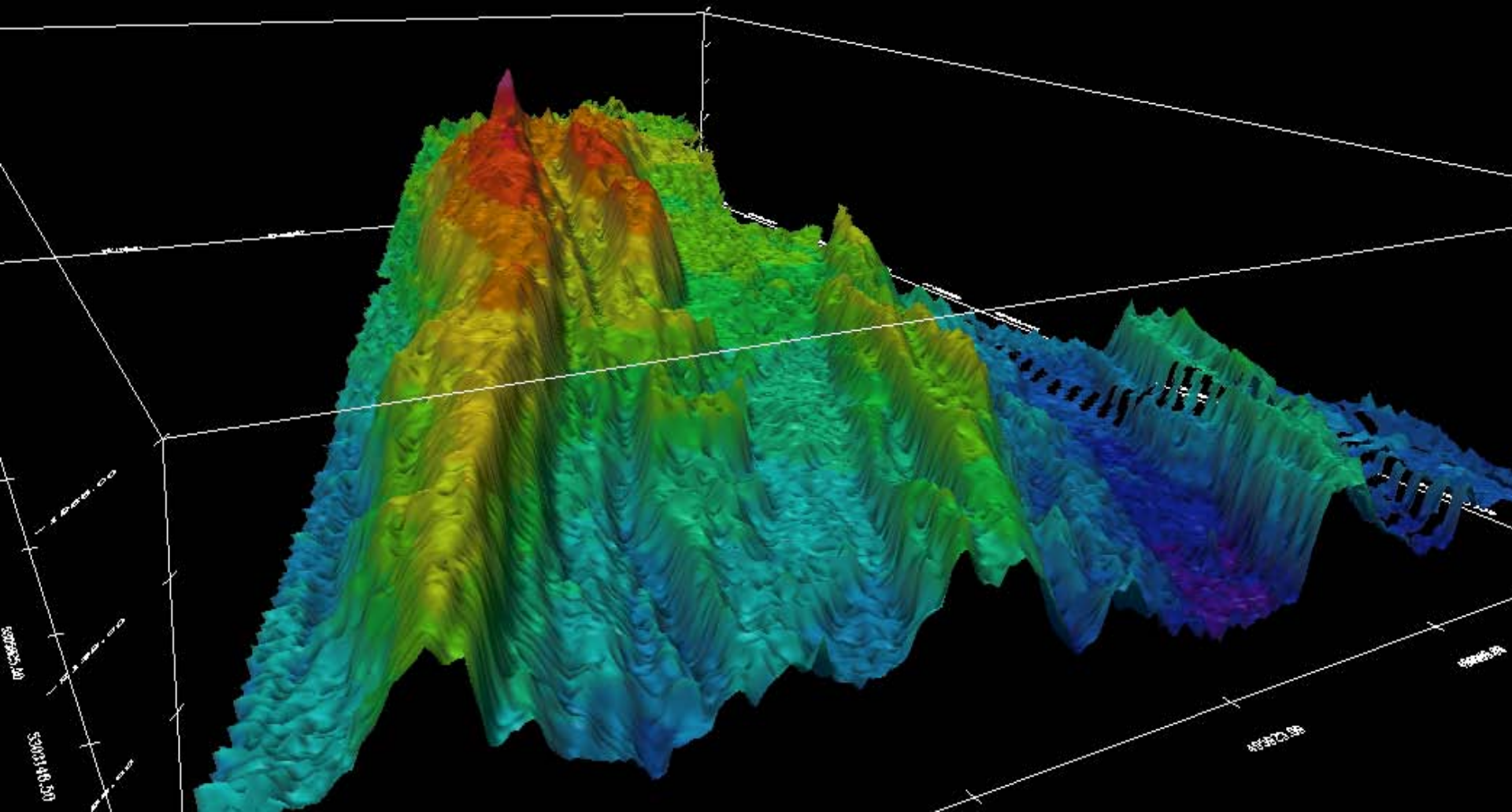

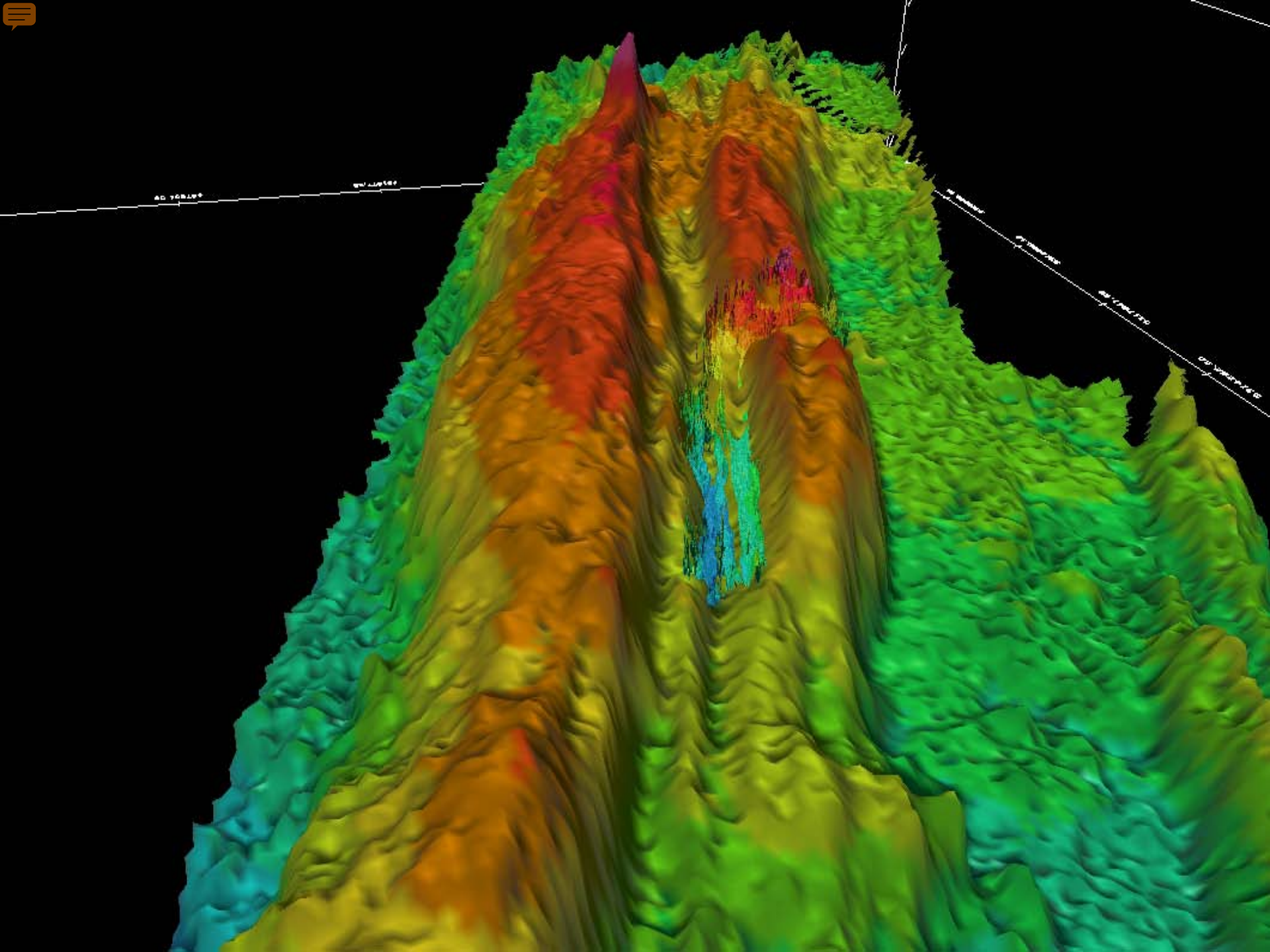

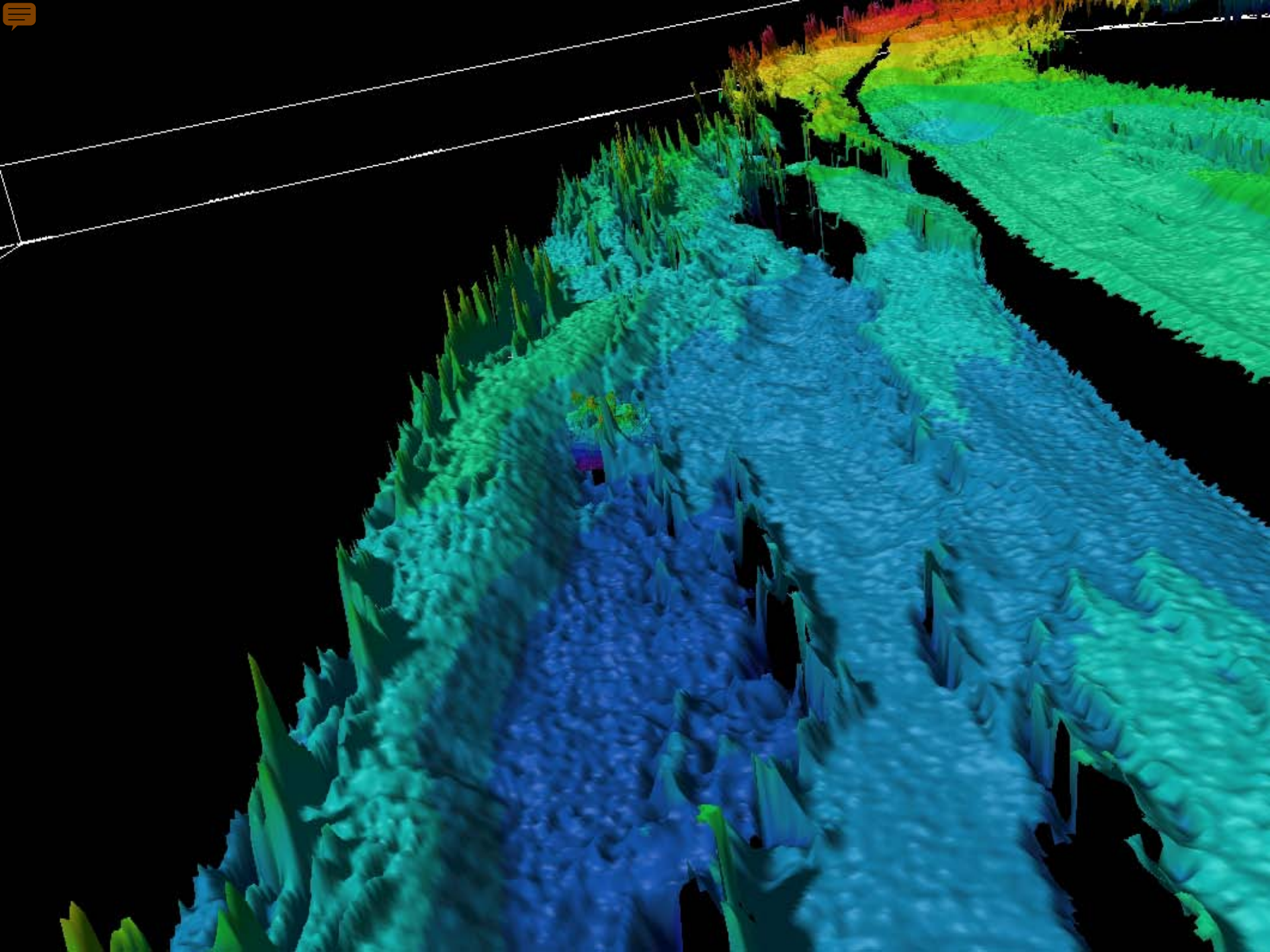

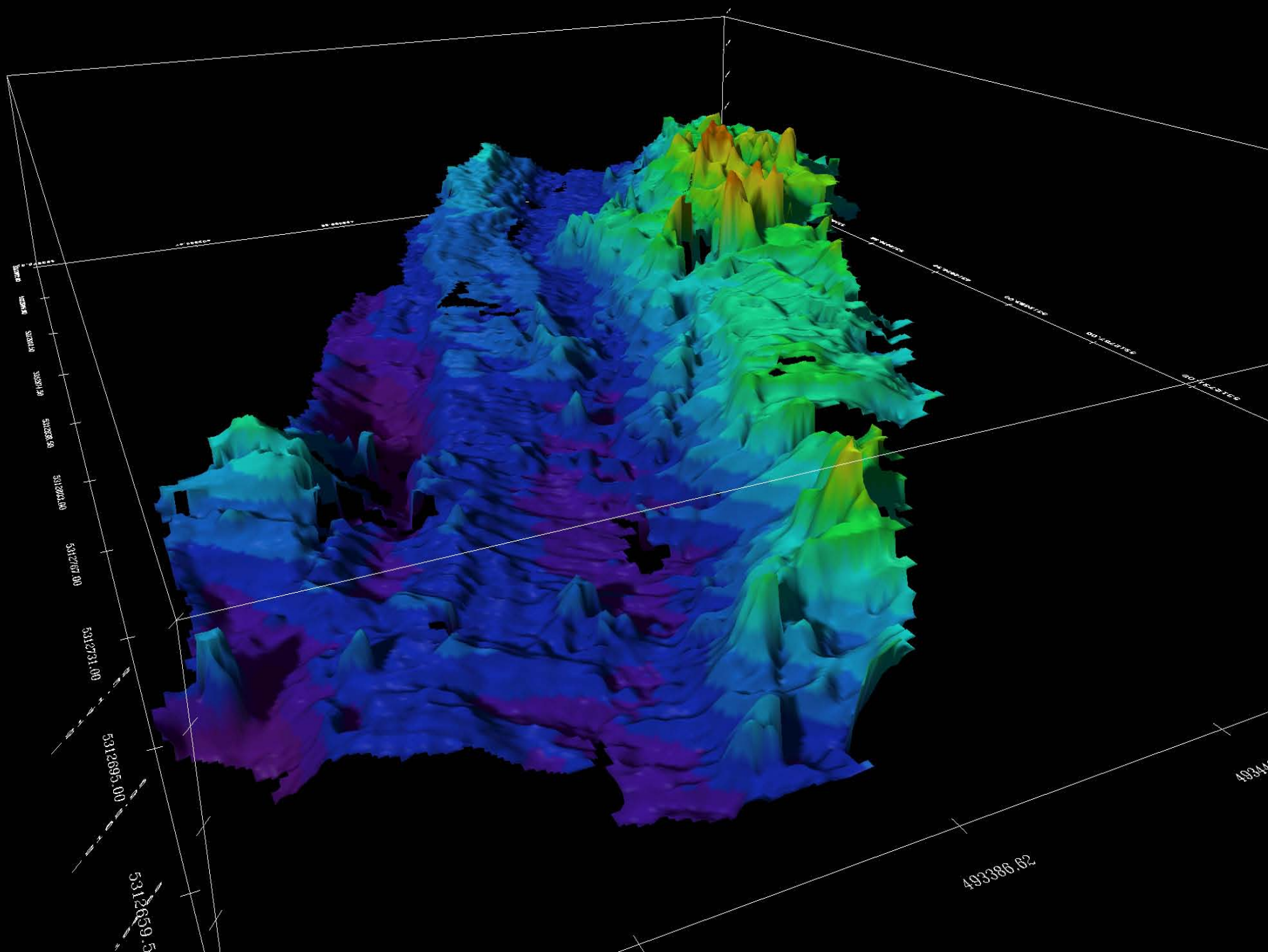



Juan de Fuca Ridge

Mothra Hydrothermal Field

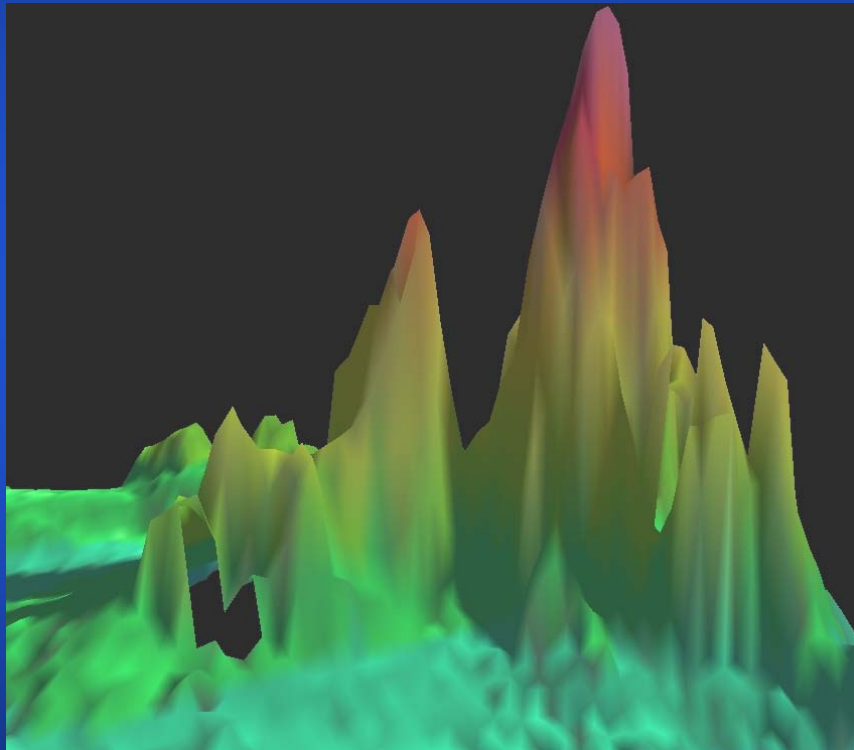

3-D acoustic image of Mothra field from Imagenix sonar data



Photomosaic of Mothra field generated by Univ. of Washington

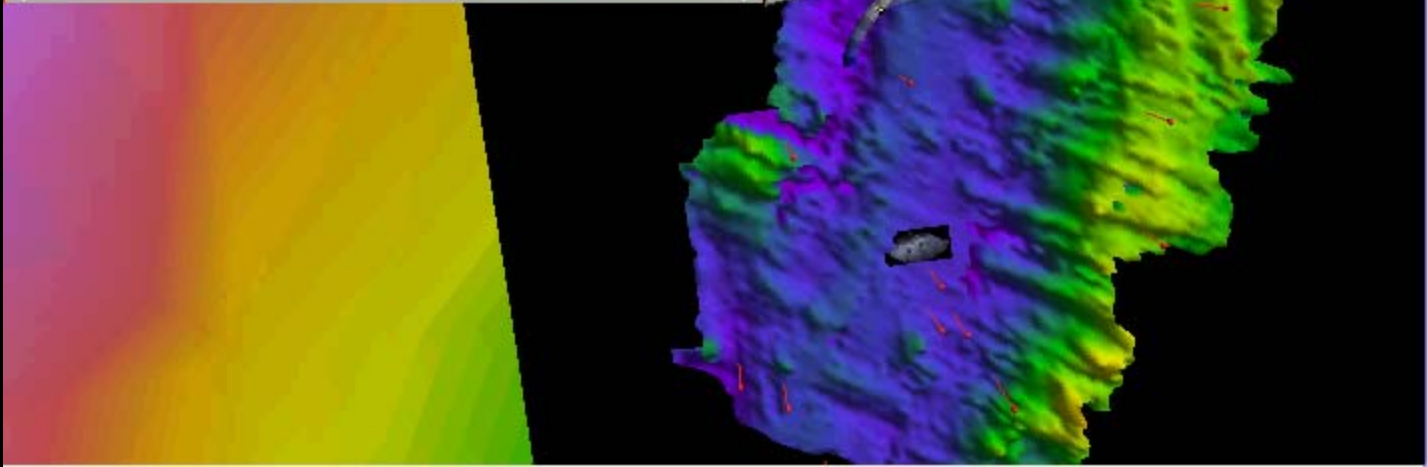
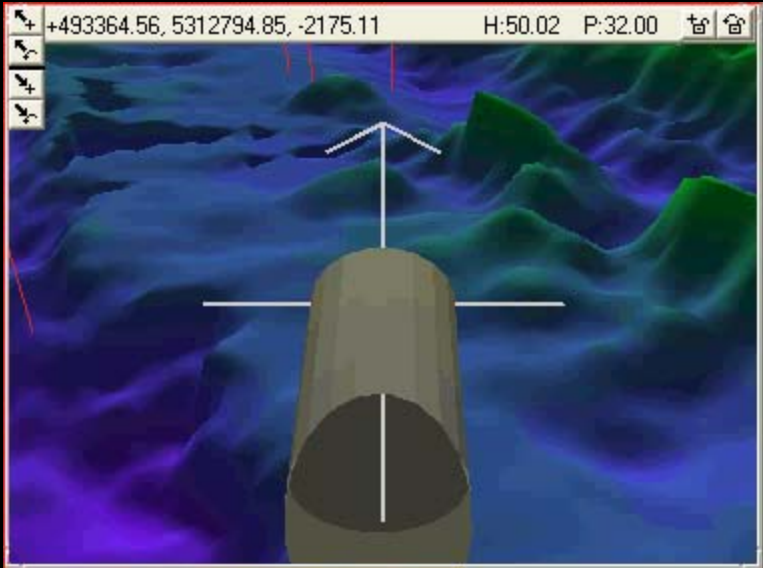



Real-time 3-D visualization of AUV data

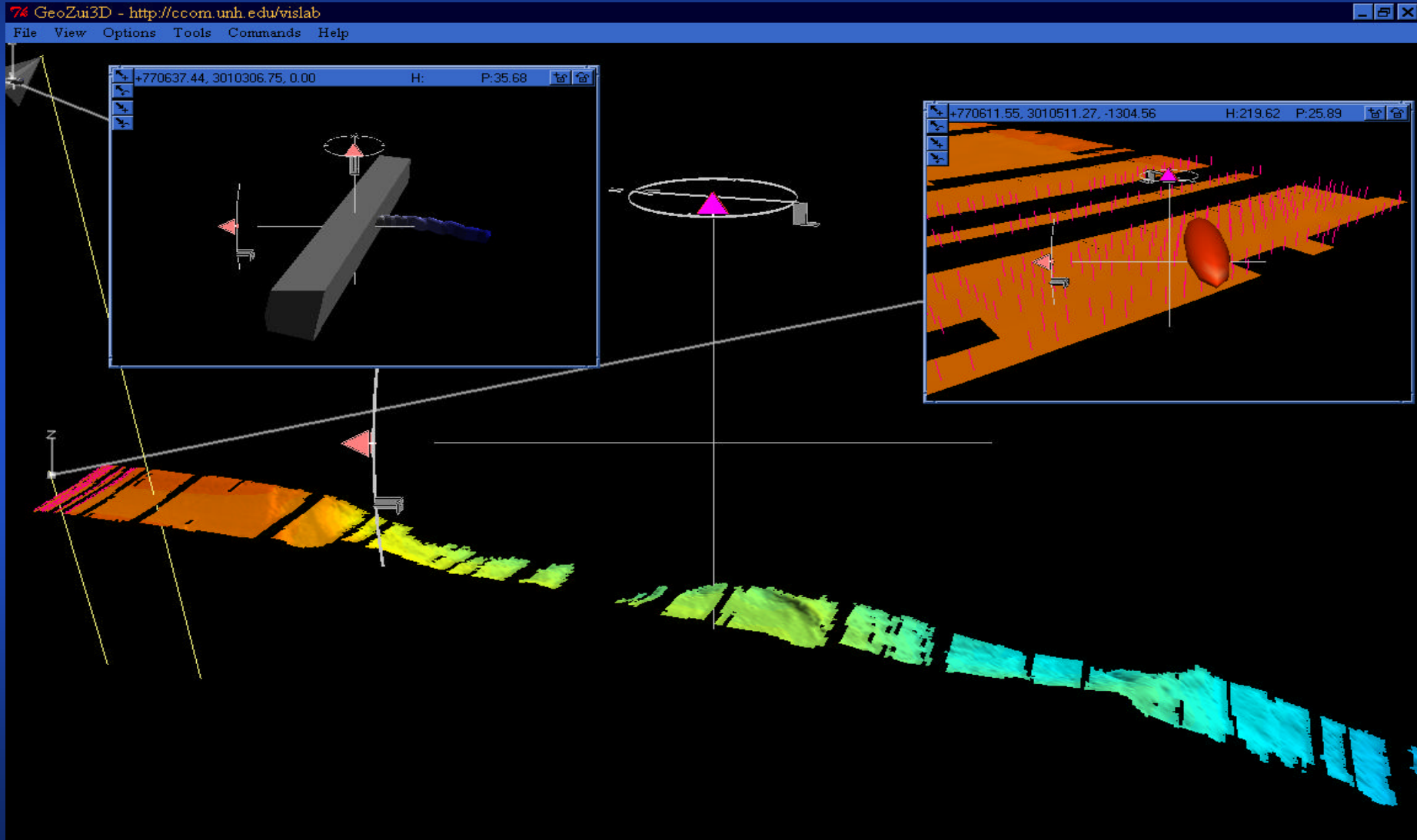



PROCESSING:

- Faster
- Cheaper
- Better



CUBE

Combined Uncertainty and Bathymetry Estimator --

Brian Calder

Hand Edited – 48 hours

4820m

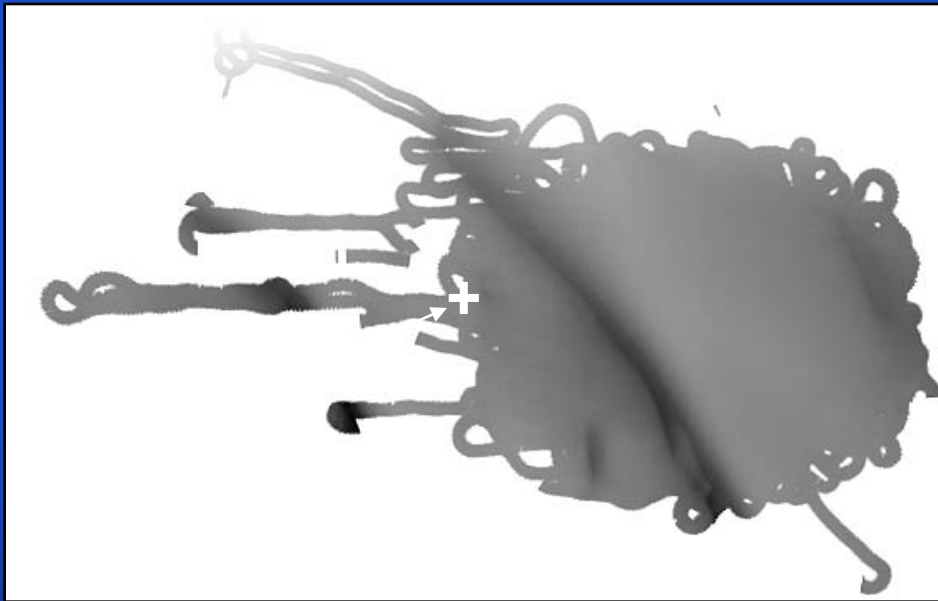

Projection: Mercator
Ellipsoid: WGS84

CUBE Edited – 10 minutes

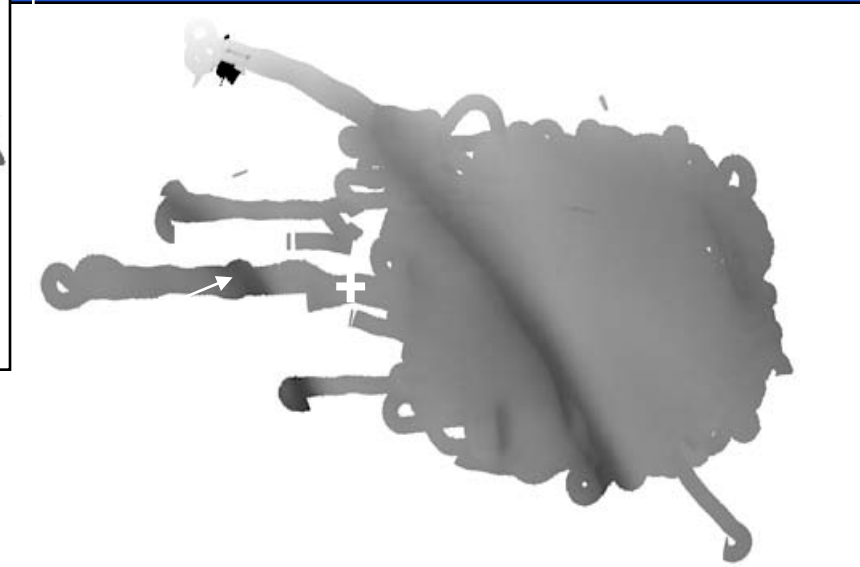

Projection: UTM
Ellipsoid: WGS84



CUBE

Combined Uncertainty and Bathymetric Estimator

Output Surface Data

Depth Estimate

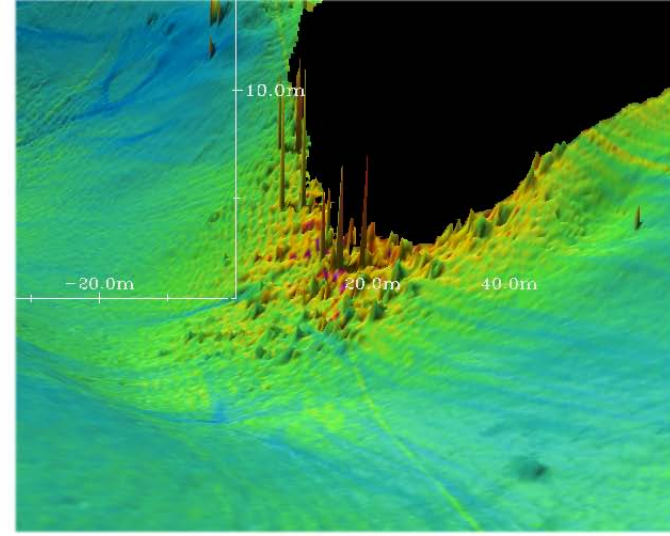
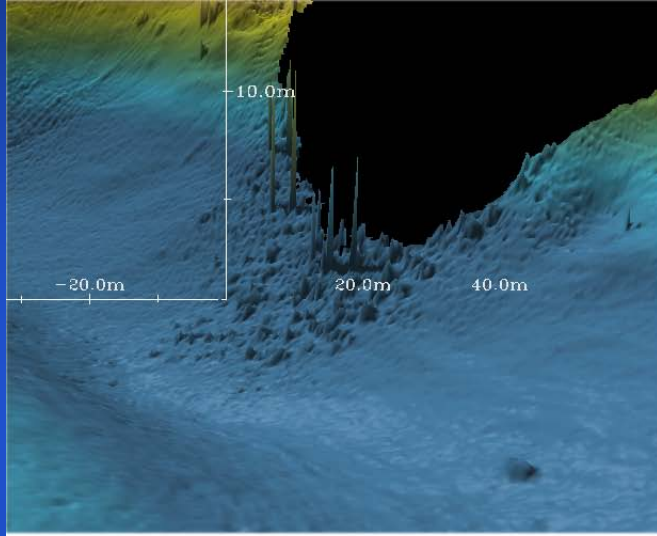

Uncertainty Estimate

Num. Hypotheses

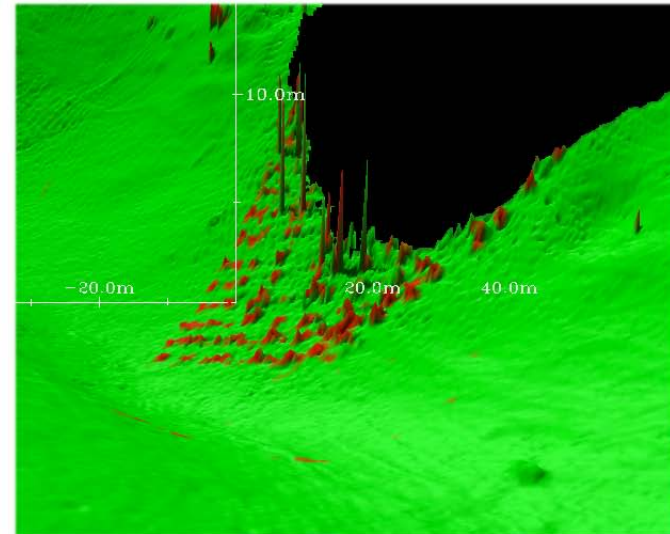
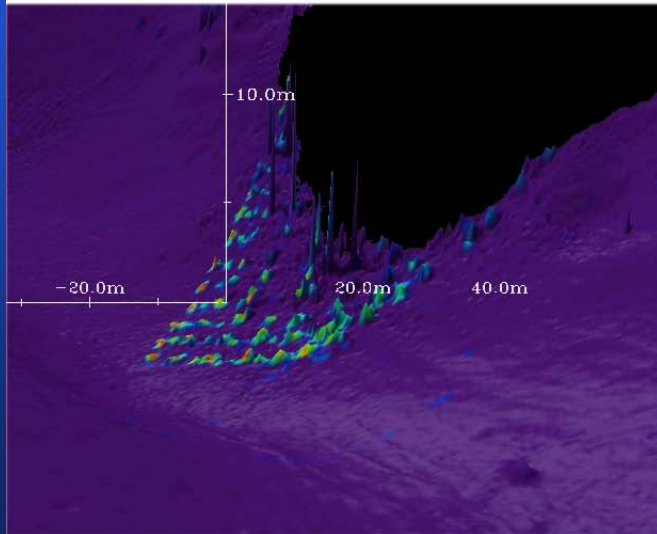

Hypothesis Strength



Example: Wood's Hole, MA

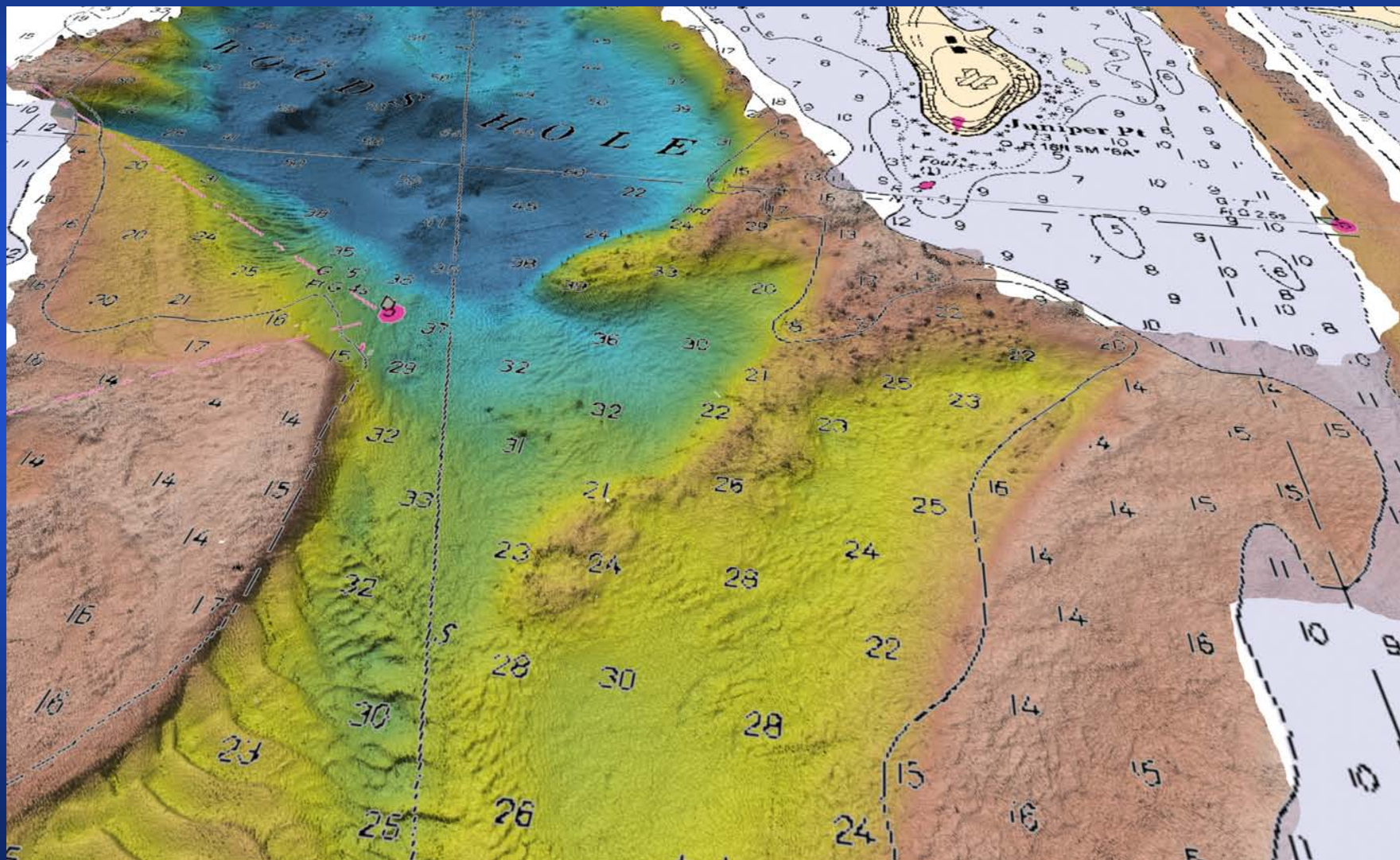



Example: Wood's Hole, MA

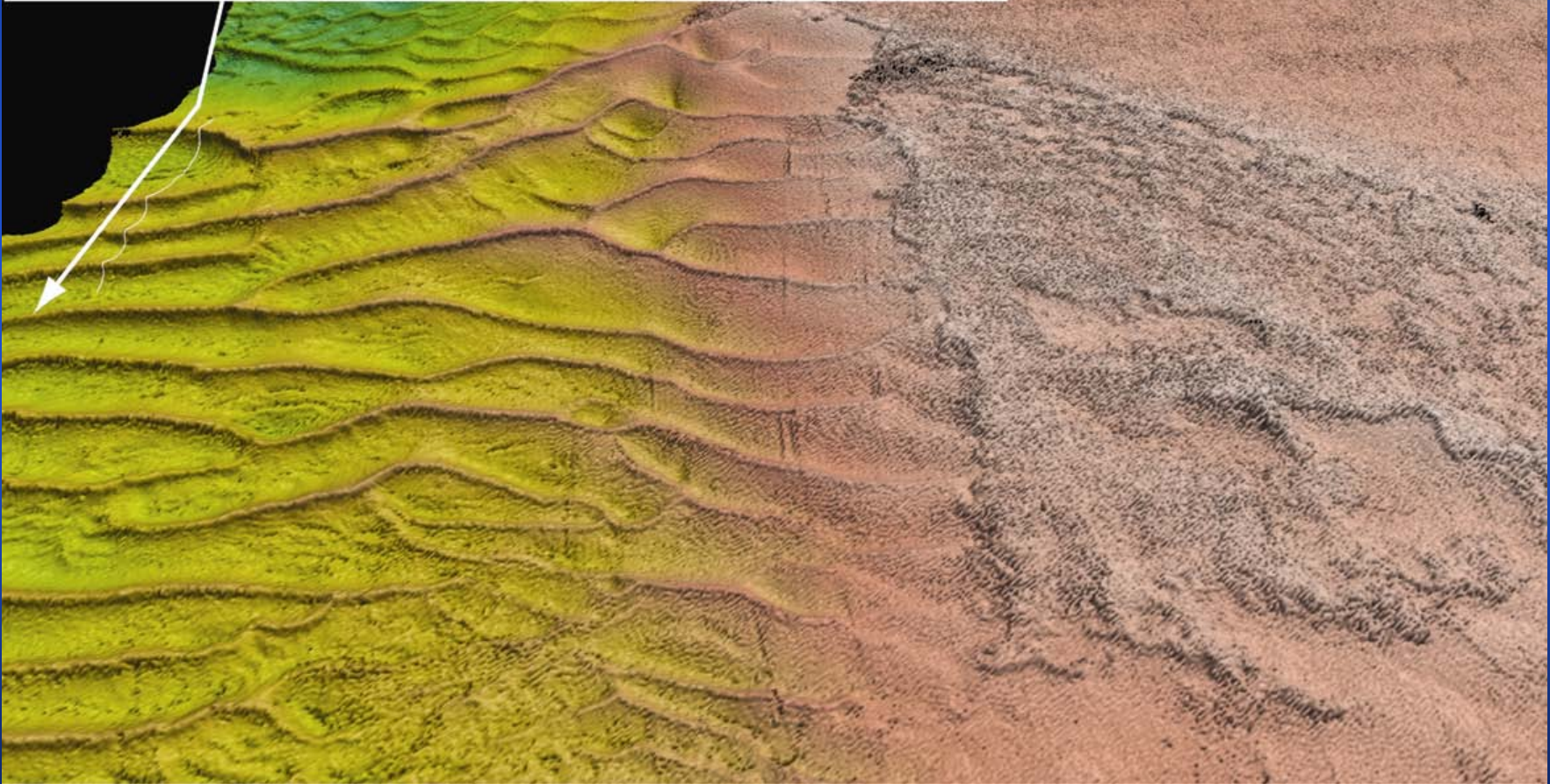
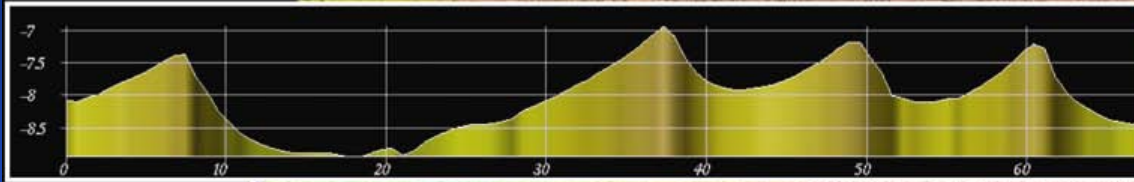



Example: Wood's Hole, MA

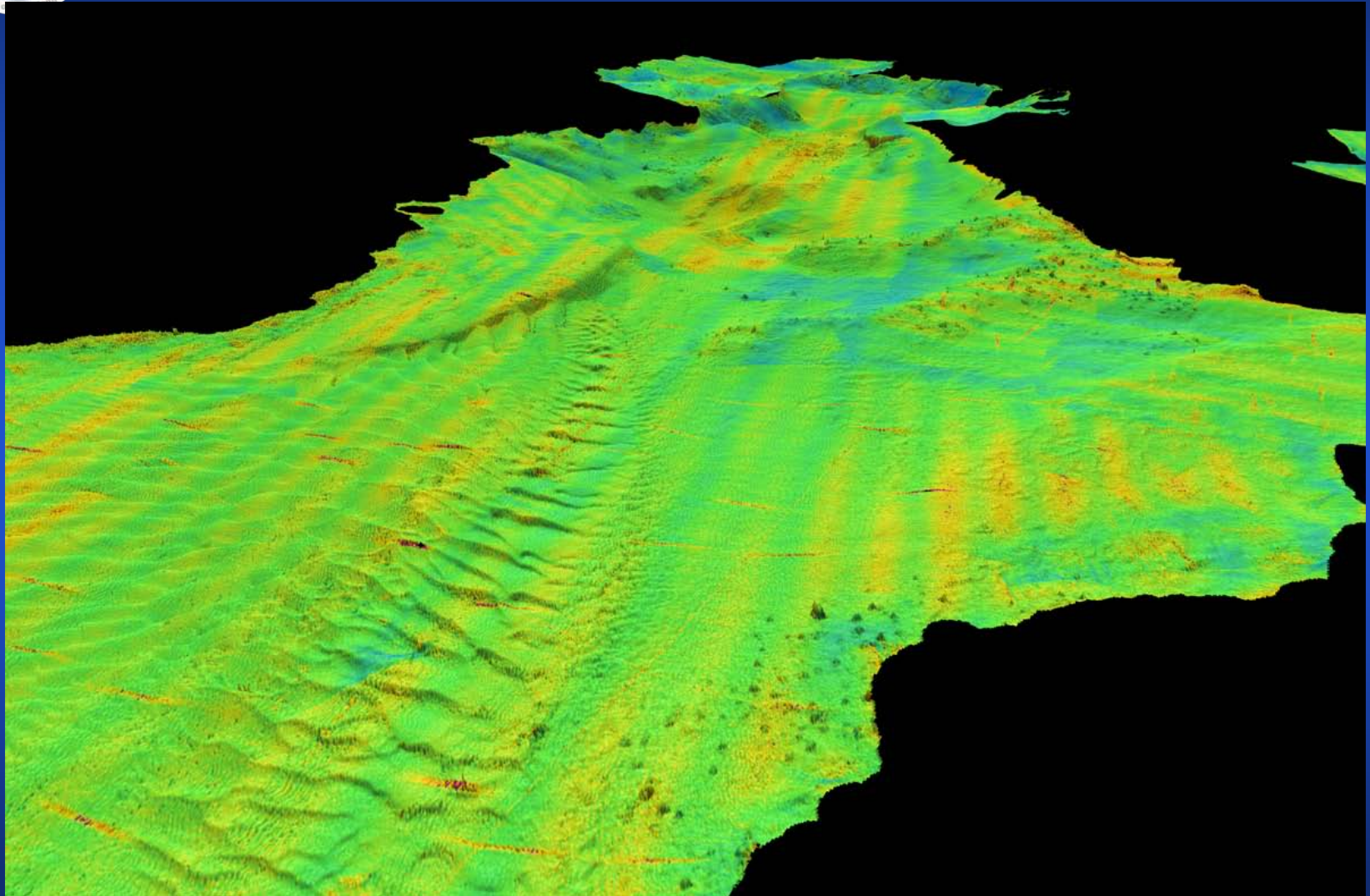

Uncertainty



NAVO AREA-BASED EDITOR in Fledermaus:

Profile Control

Y-Scale: 11.4 End Points: [-88.751838 30.165564] [-88.750771 30.165718] Distance: 94.0

Area Bounds

North lat : N 30 9.989714
 West lon : W 08 45.124477 East
 South lat : N 30 9.846475

Sounding Control

Surface Display: Average Transparency
 Show Surface: [] Shade Surface
 Color: Snd. Density []
 East Gate: Mesh Gap: 10

Target Display

Target Snippet Control
 Load Image Draw Image Close

Target Info

Description: LIBERTY SHIP
 Remarks: NORTH END OF 1e-1
 Snippet Image: trg93.png Change File

Pick

- Soundings
- Geo-Picking
- Cell Picking
- Centre-On Pick
- Show ChMap
- Bounding Coords
- Geo-Reference
- Geo-Reference Units
- Easting/Northing
- View Manager
- # Profile Points: 160

Raw Line	Name	ID	Number	Pen	Sensor	Dep.	Sensor SV	Profile	W/E	East	W/E	North	Latitude	Longitude	Depth	XYZ Position
0	4	1131	38	0	0	0	0	0	0	328.081	328.0814	30.1458256	-88.750814	-88.750814	-14.277	0.000
1	4	1136	39	0	0	0	0	0	0	328.081	328.0814	30.1458256	-88.750814	-88.750814	-14.461	0.000
2	4	1131	38	0	0	0	0	0	0	328.081	328.0814	30.1458256	-88.750814	-88.750814	-14.461	0.000
3	4	1132	39	0	0	0	0	0	0	328.081	328.0814	30.1458256	-88.750814	-88.750814	-14.461	0.000
4	4	1136	36	0	0	0	0	0	0	328.081	328.0814	30.1458256	-88.750814	-88.750814	-14.411	0.000
5	0	2914	11	0	0	0	0	0	0	328.081	328.0814	30.1458256	-88.750814	-88.750814	-14.431	0.000

Profile Control

Y-Scale: 8.28 End Points: [-88.749931 30.165163] [-88.749406 30.165168] Distance: 52.1 Save Profile: []

File Options

Redraw Resat PolyZoom Zoom In View Single Swath View All Swaths View Mosaic
 Display Contours View Invalid Data View Flagged Data View Suspect Data
 Plan View South View East View Select View Move Target Delete Target

Position Info

View angle : 360.0 Z Value : 7.863008

THE “NAVIGATION SURFACE”

(Shep Smith)

- Gridded product but preserves shoal soundings
- Removes system noise
- Multiple uses and display forms
- Horizontal resolution appropriate to navigation purpose and survey horizontal uncertainty.
- Vertical resolution appropriate to data source
- Local minima shoal biased/respected
- All other areas follow a “conservative best estimate” rule

0 - 1m_wmg_w_smooth.g
1 - adjustpoints.point
2 - adjustpoints.point
3 - adjustpoints.point

Hide

Show

Set Sequence

Default

Save scene

0 - default.clut

Default:

Edit

Save Clut



PRODUCTS:

- Real-time 3-D updates and **DATA FUSION** for QC and interpretation
- Near-real-time derivative maps



A new perspective → new insights

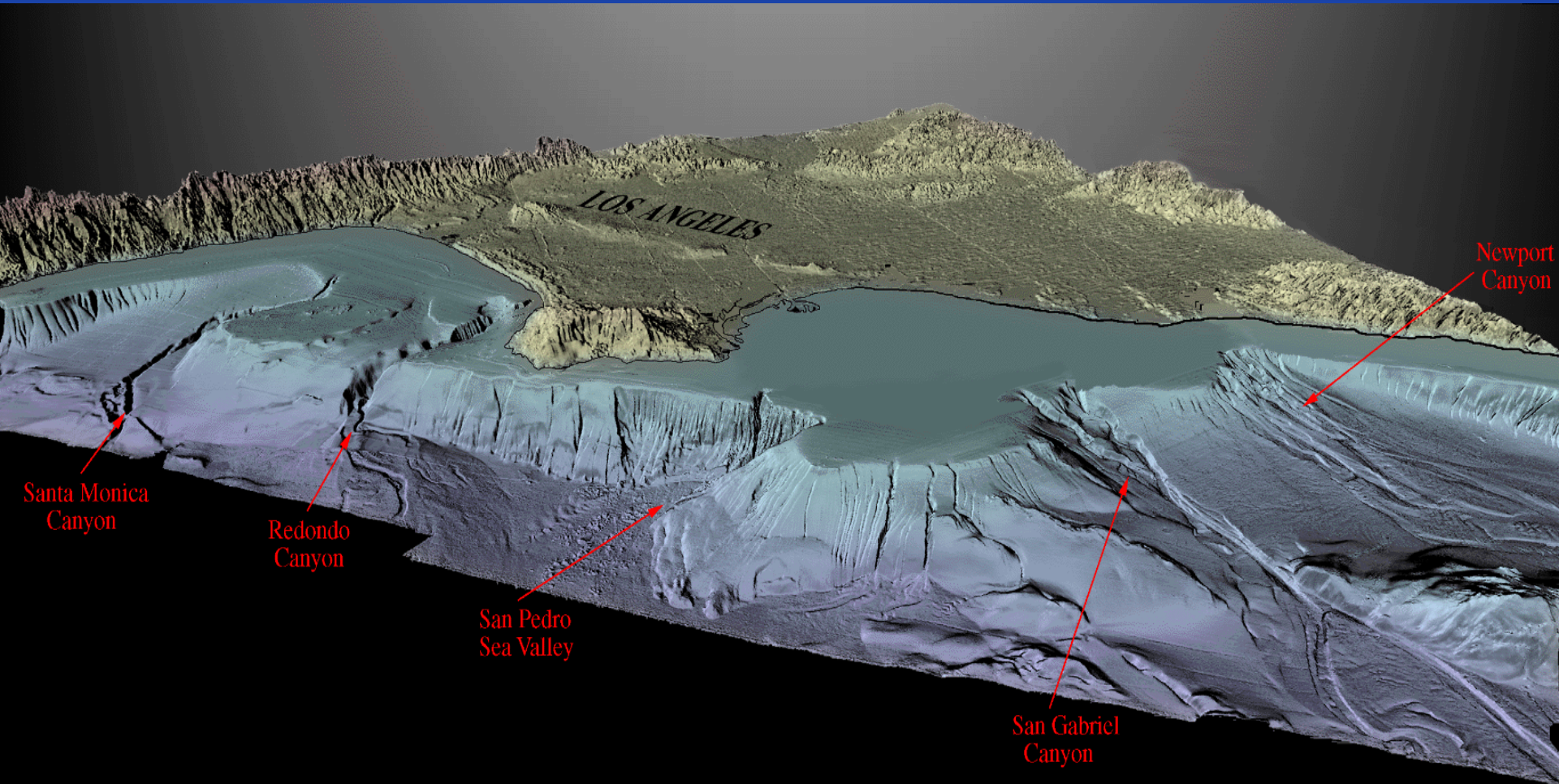

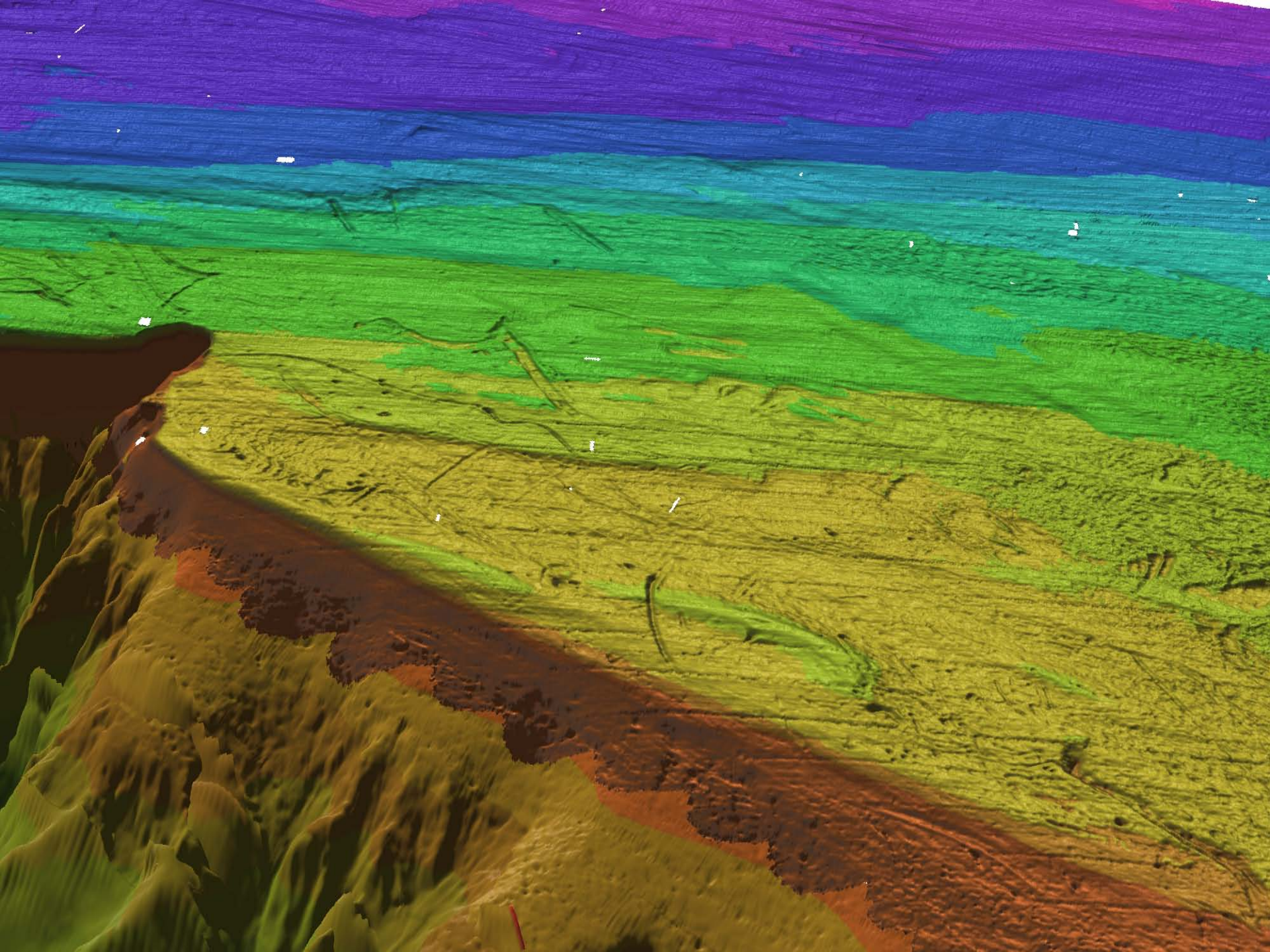

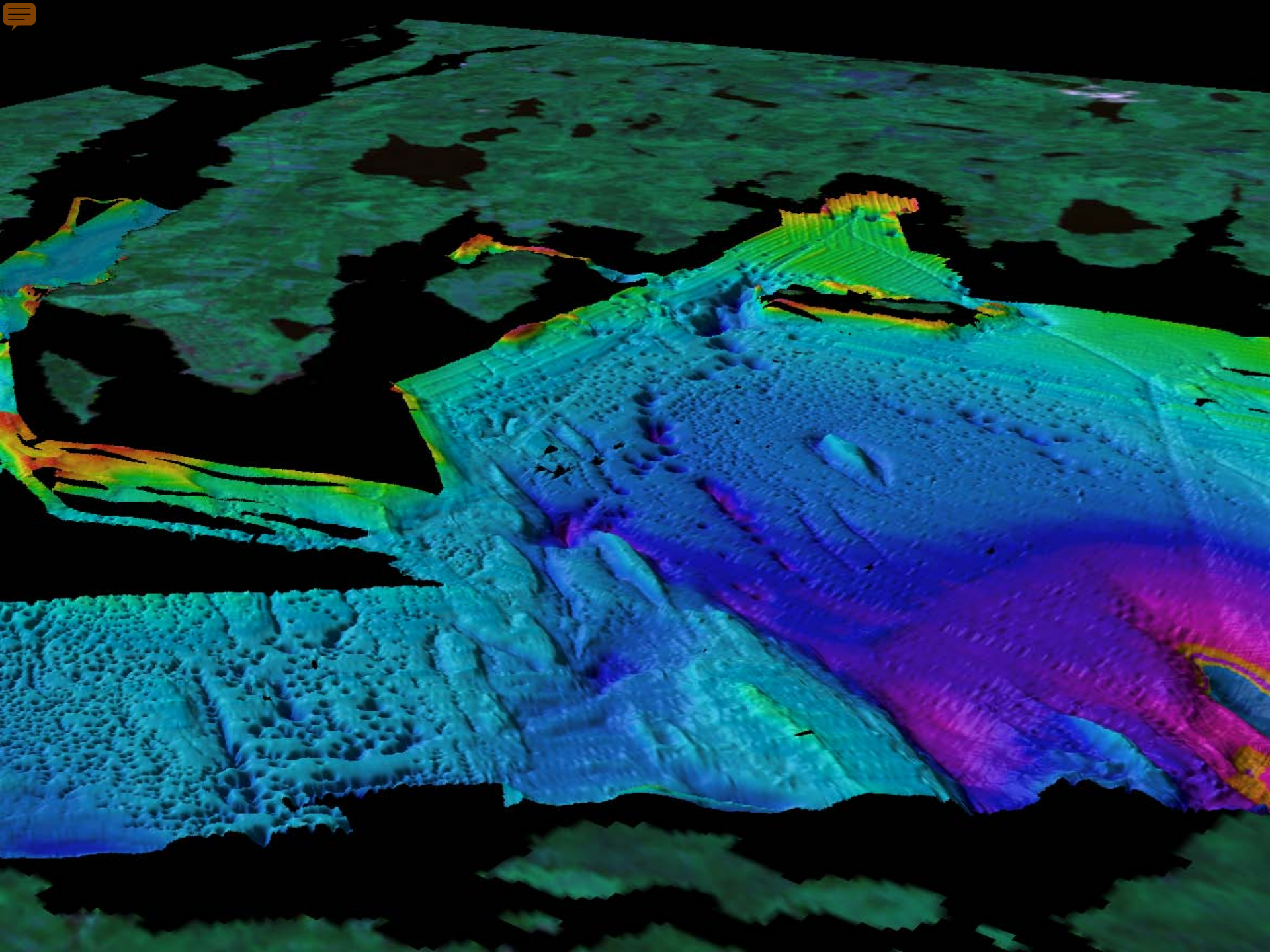

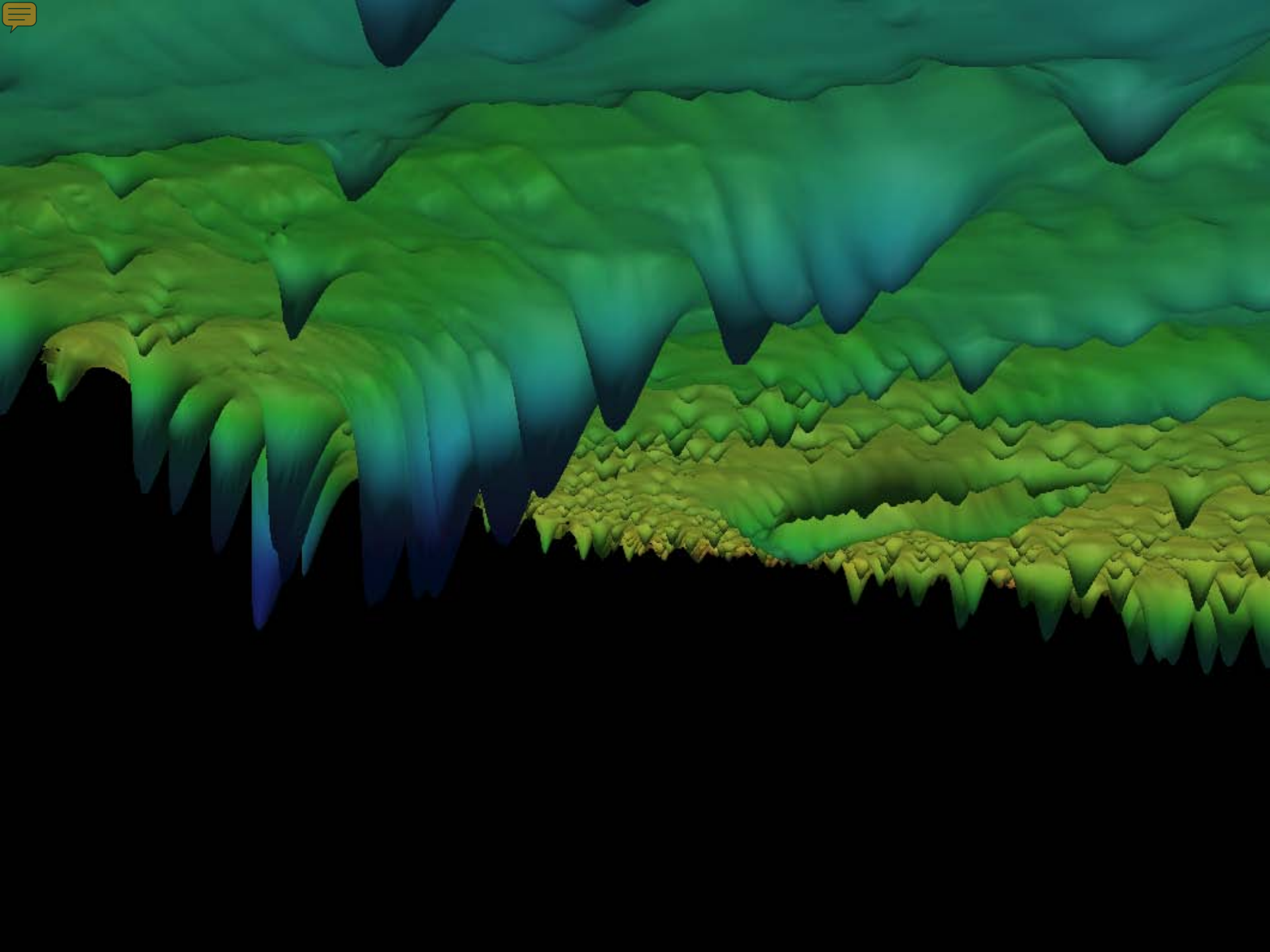

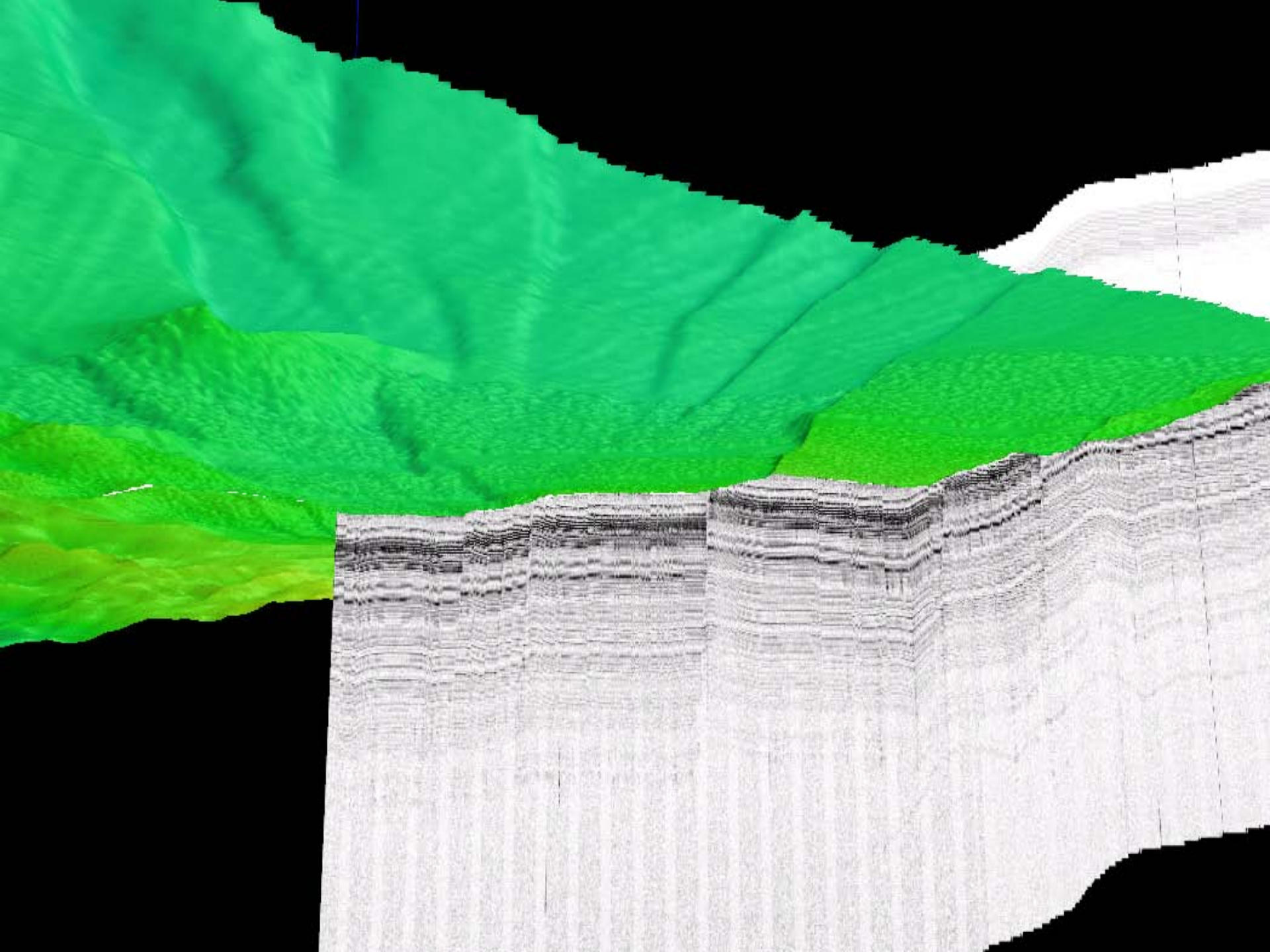



NOAA BATHY-TOPO PROJECT

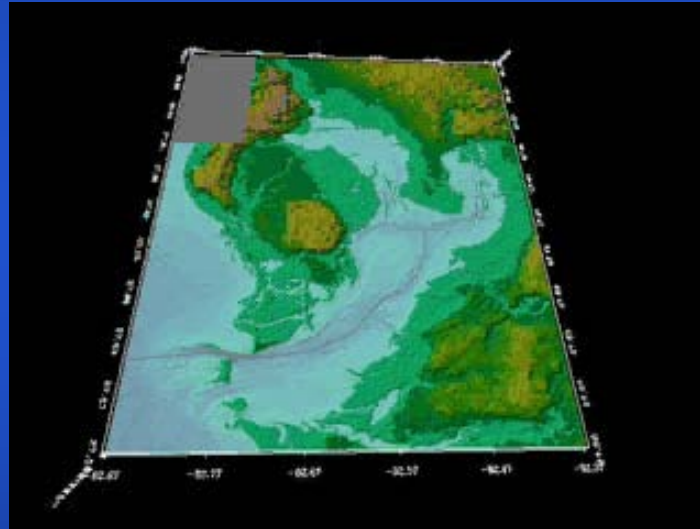

Flight into Tampa Bay, Florida

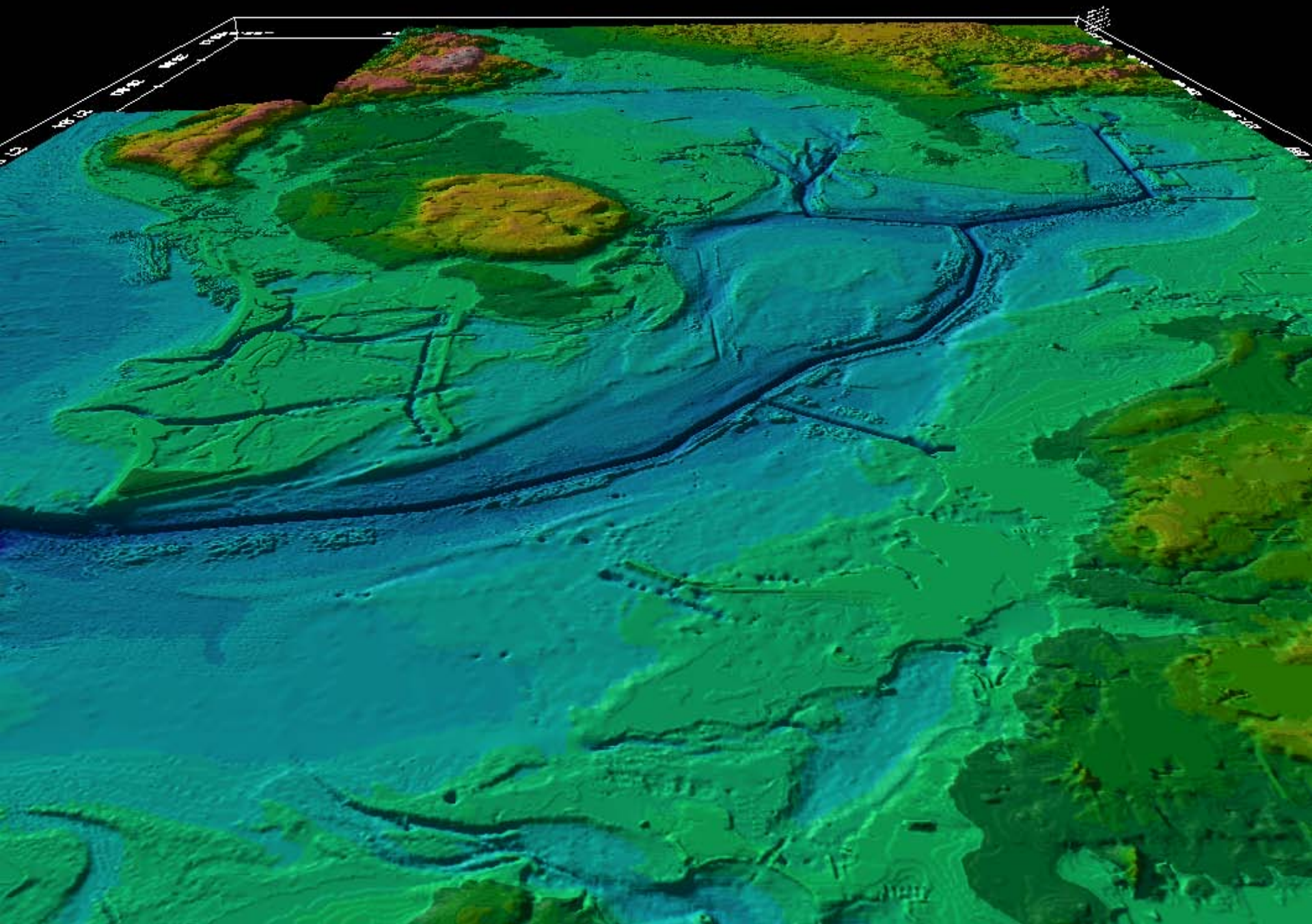

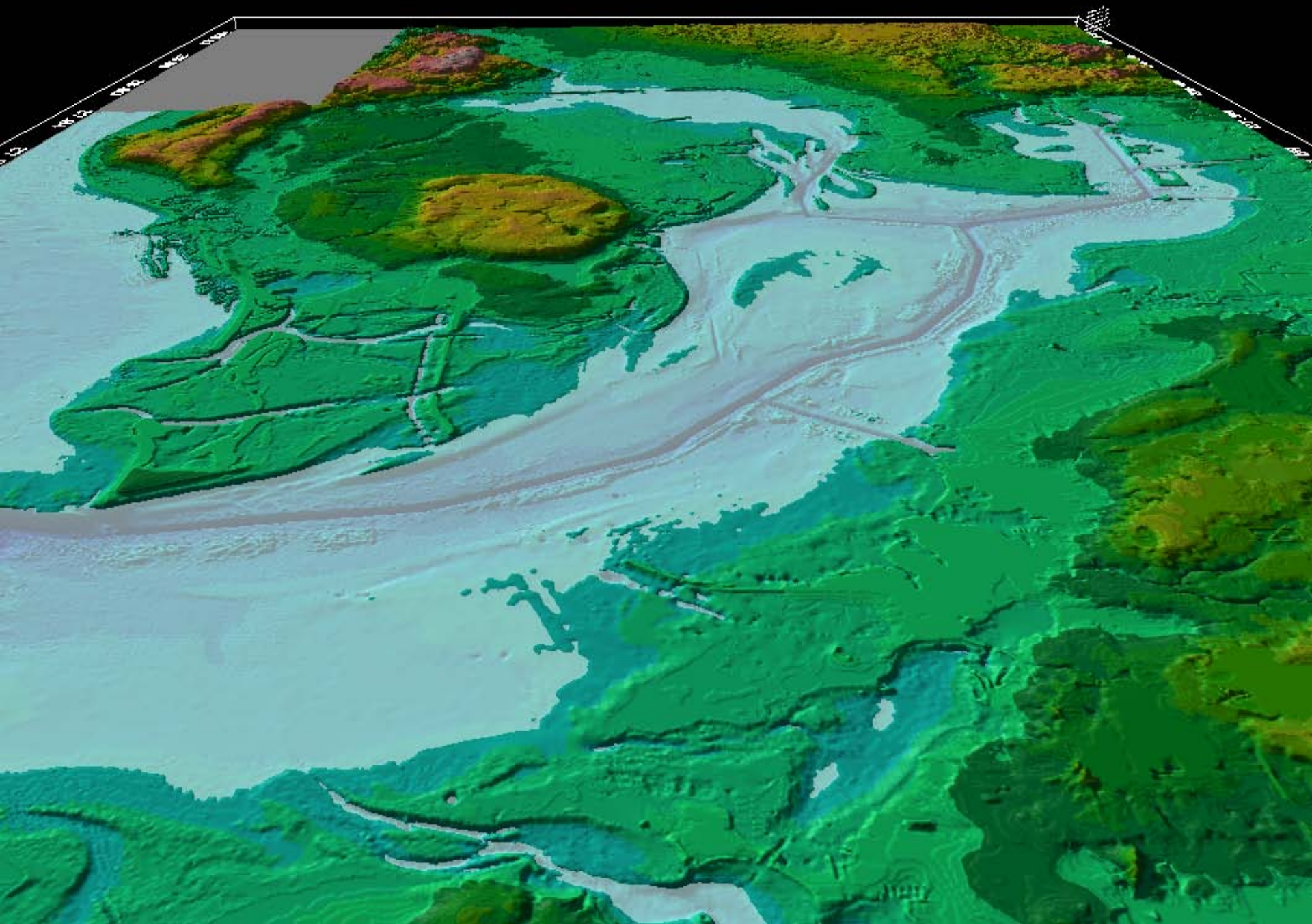

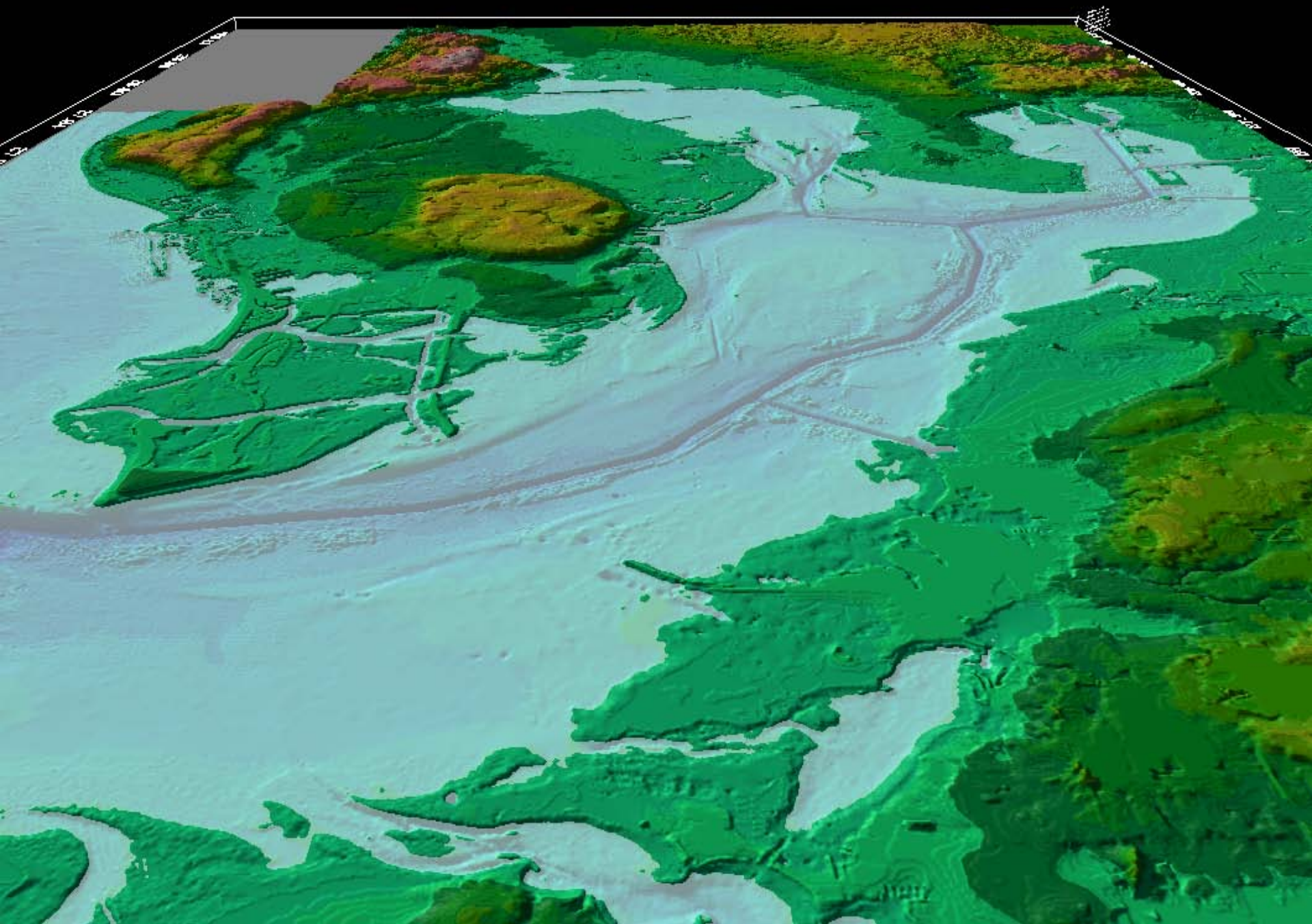

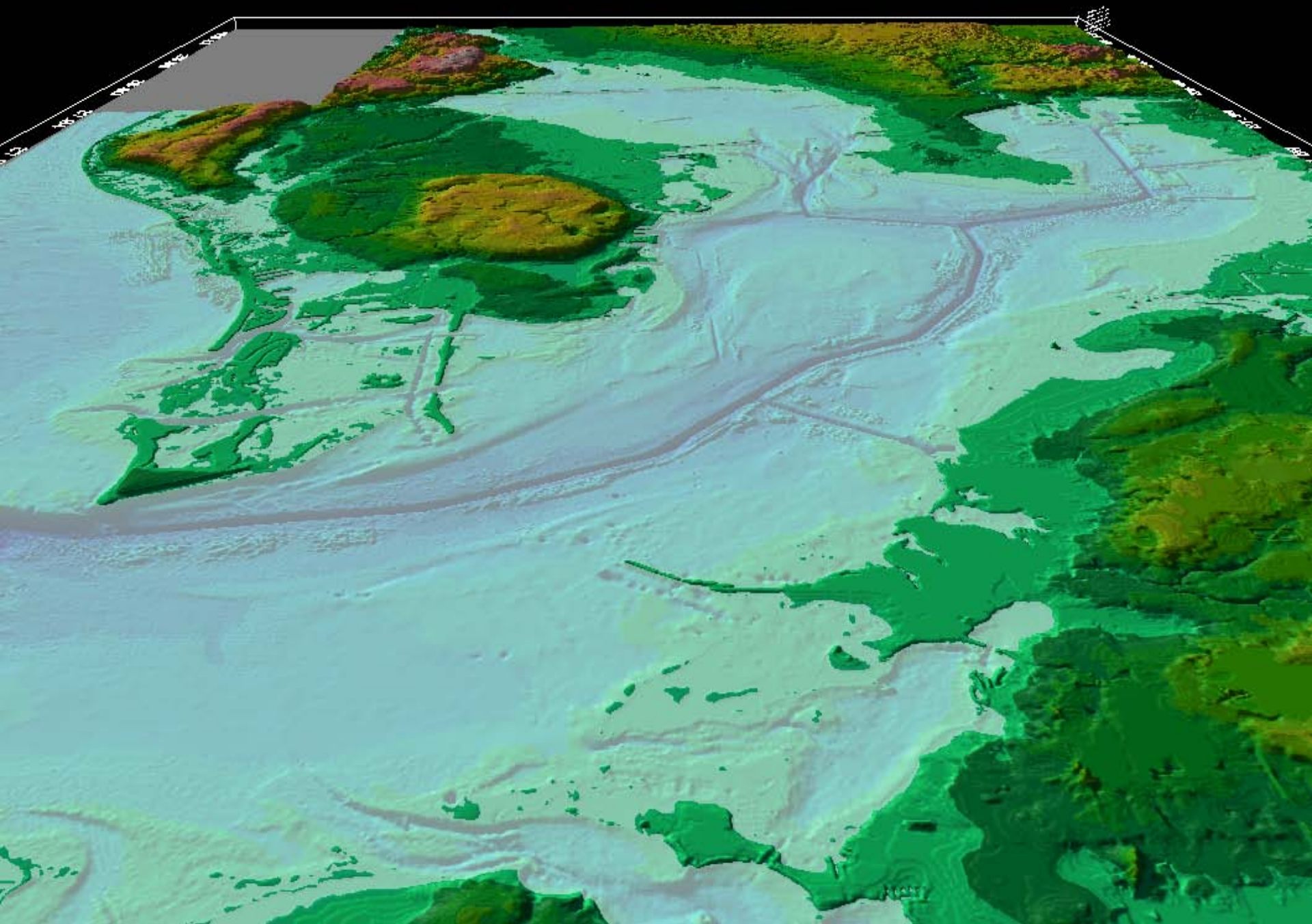

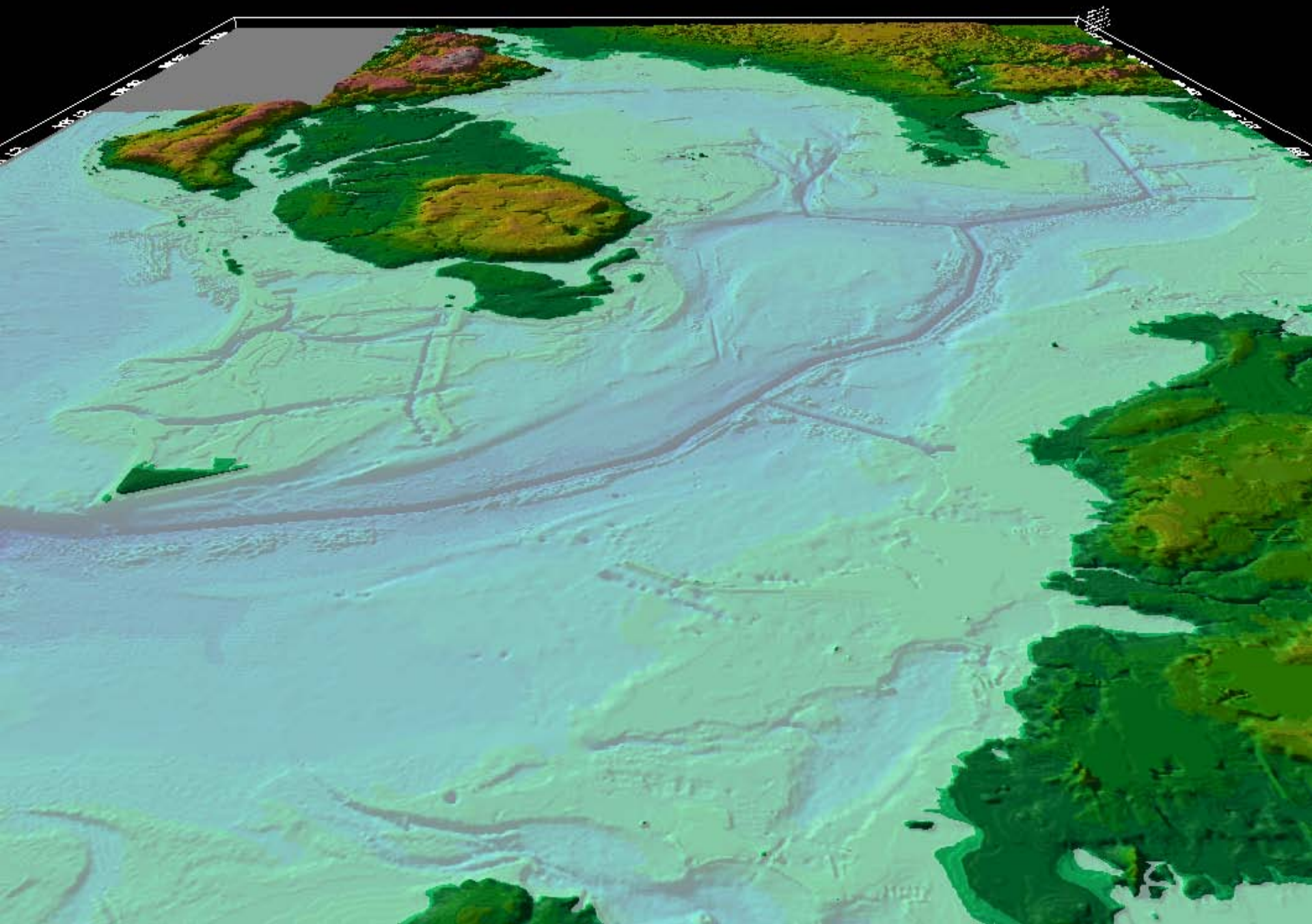

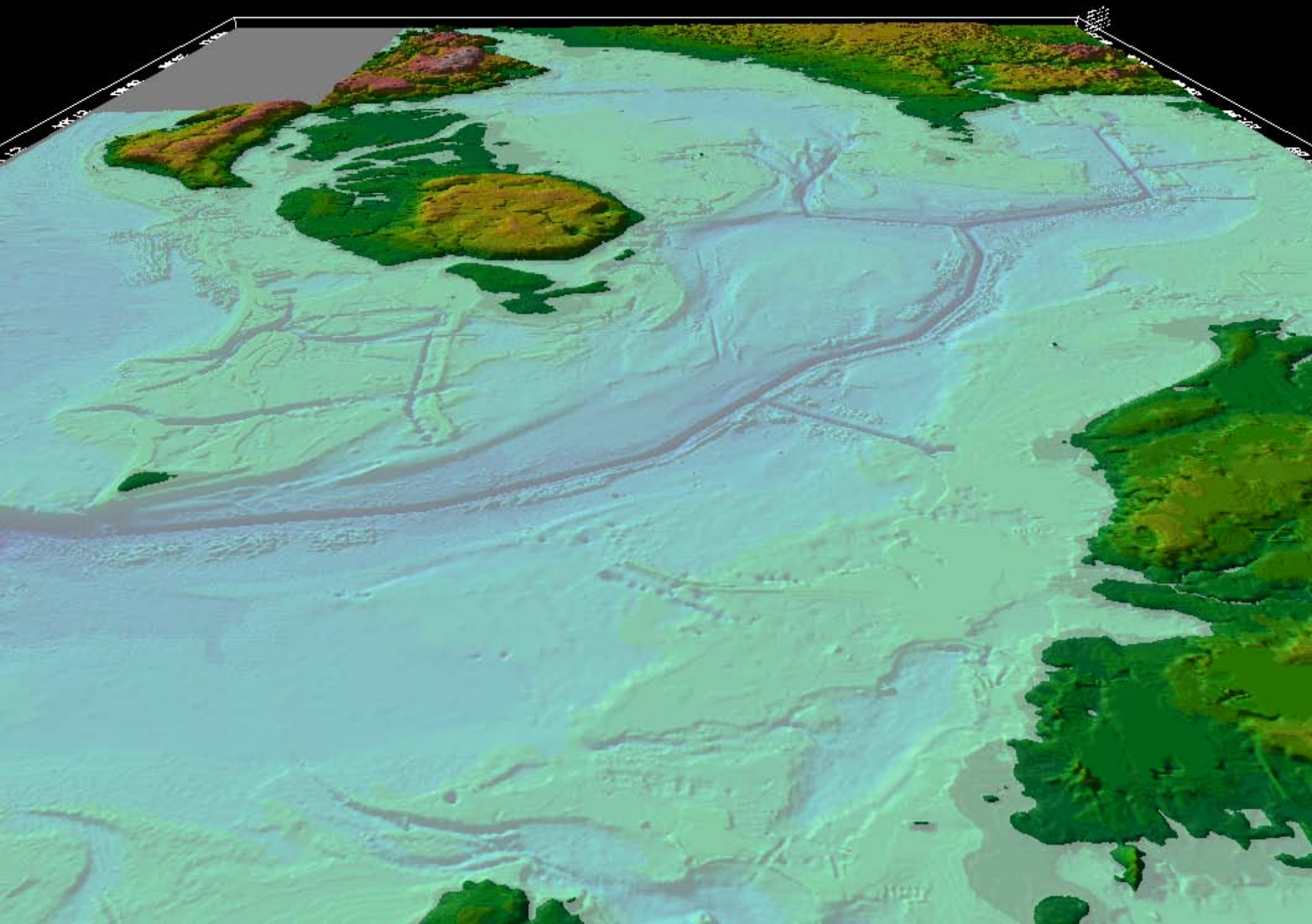

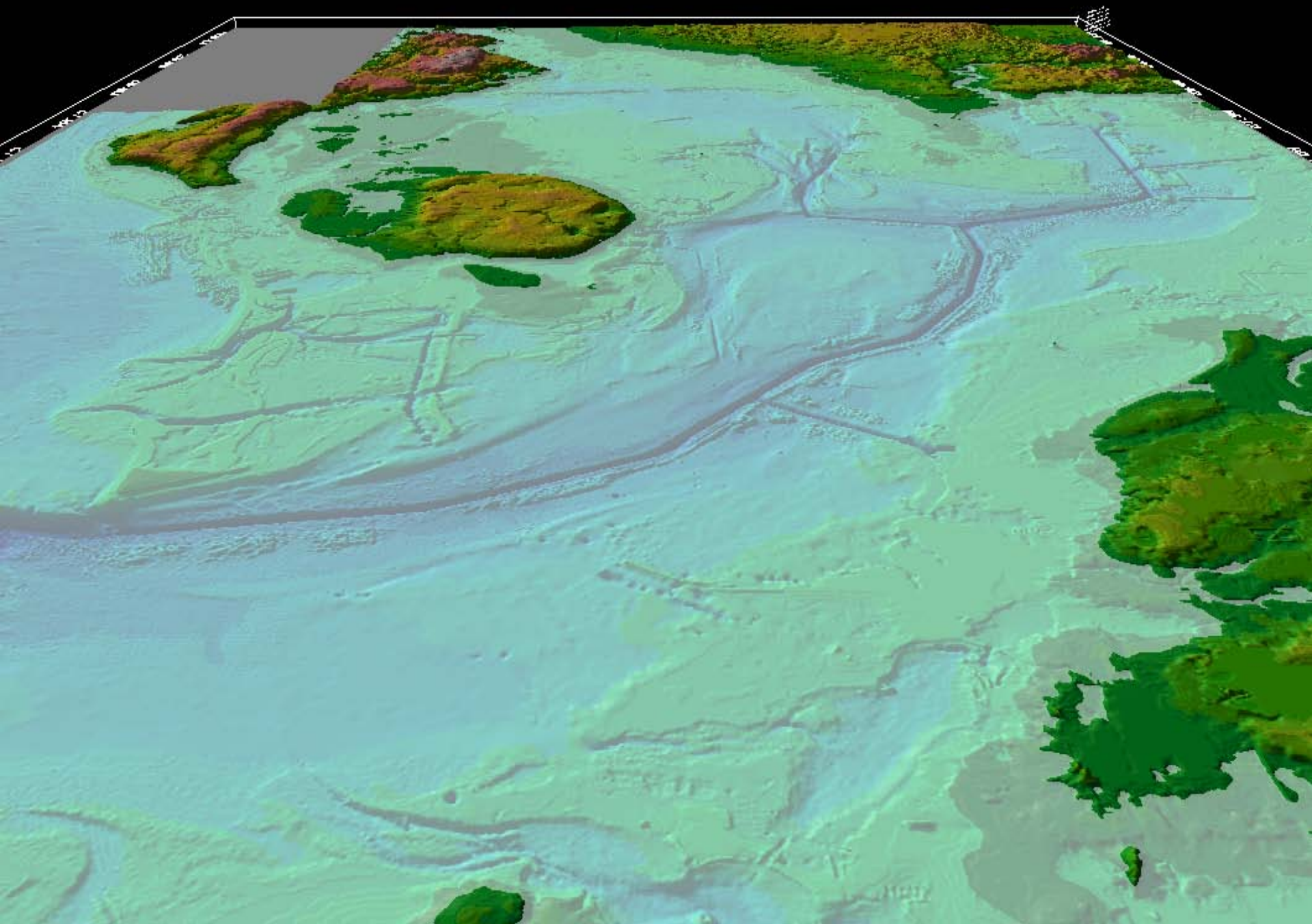

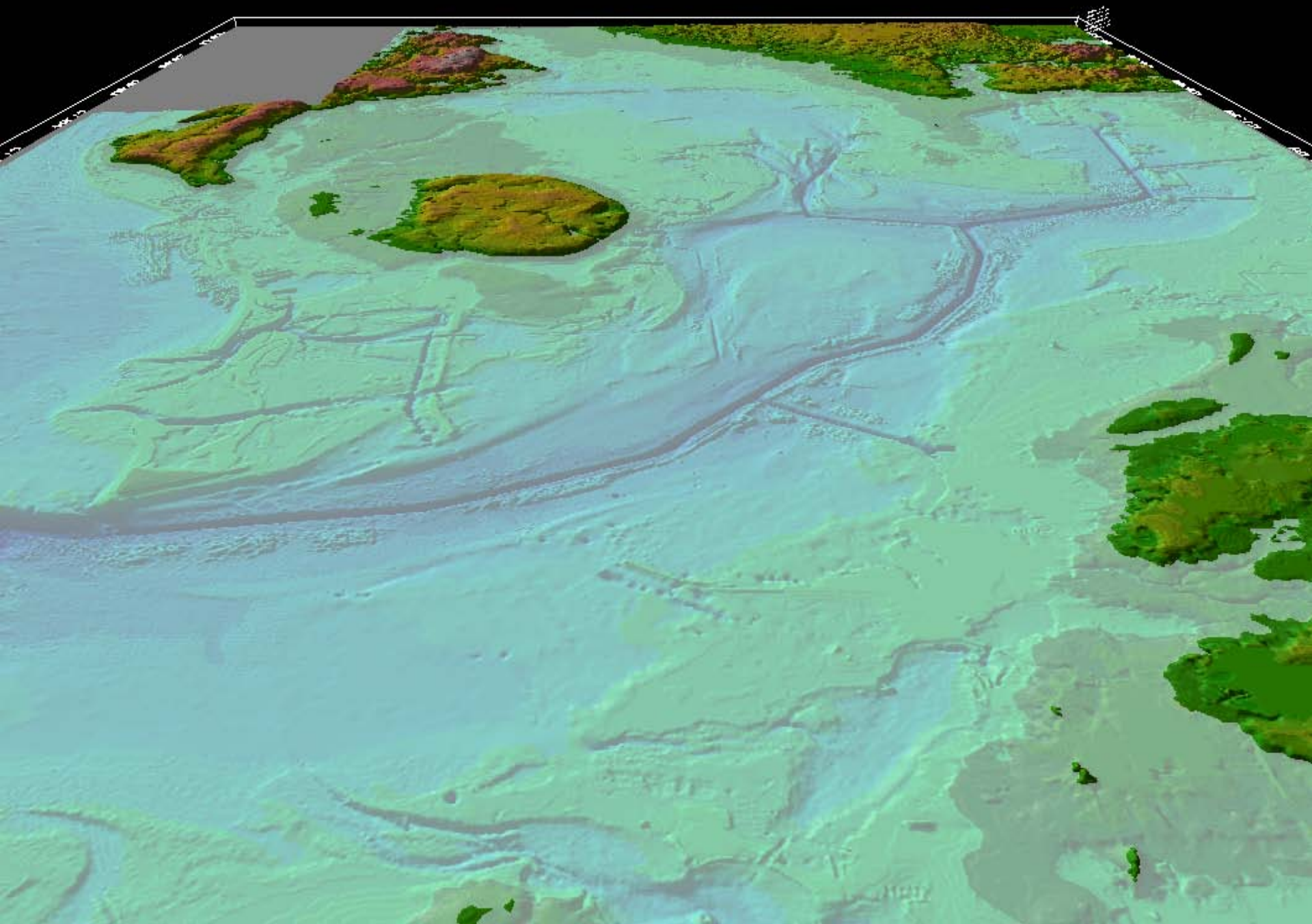

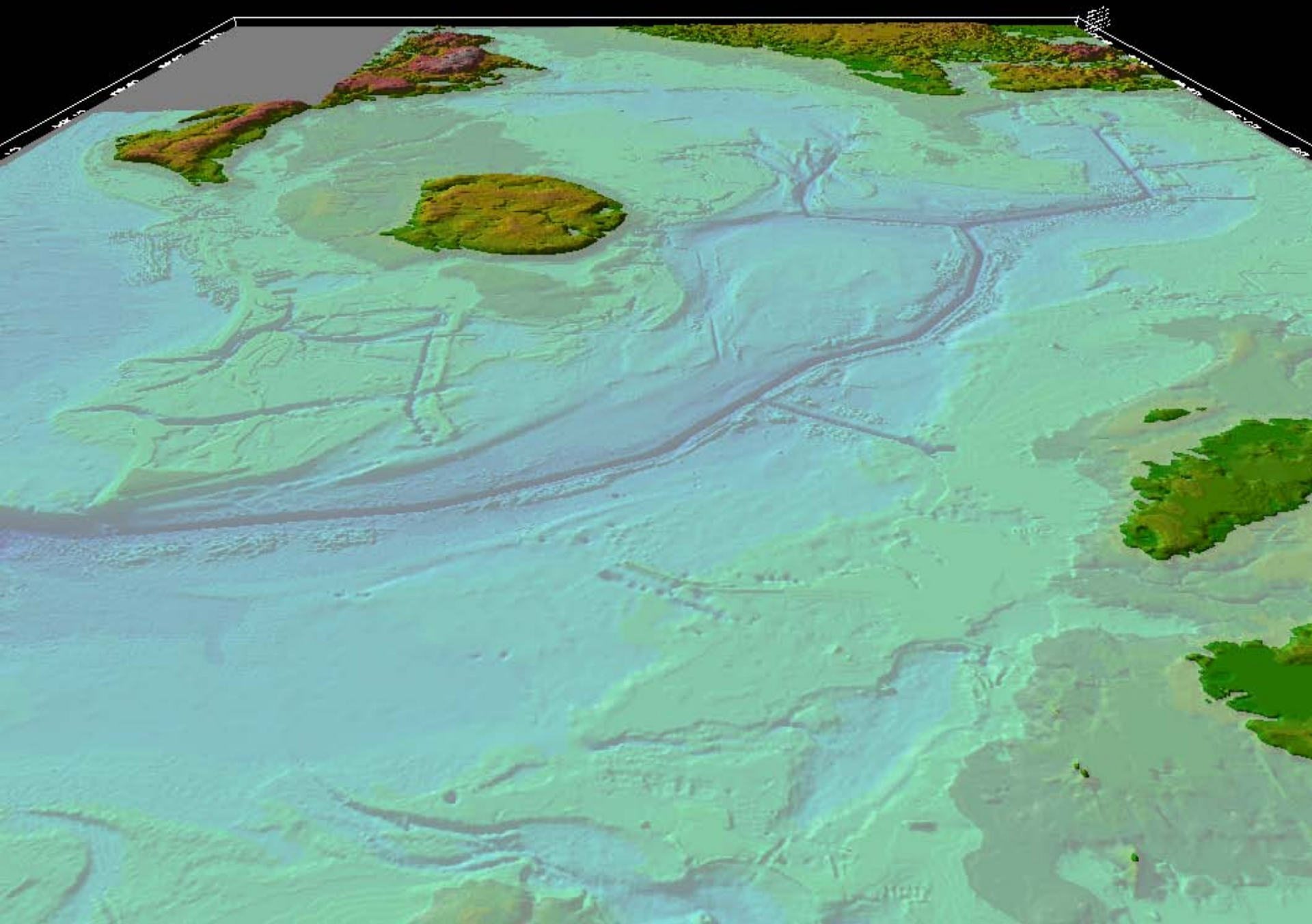

Data Fusion

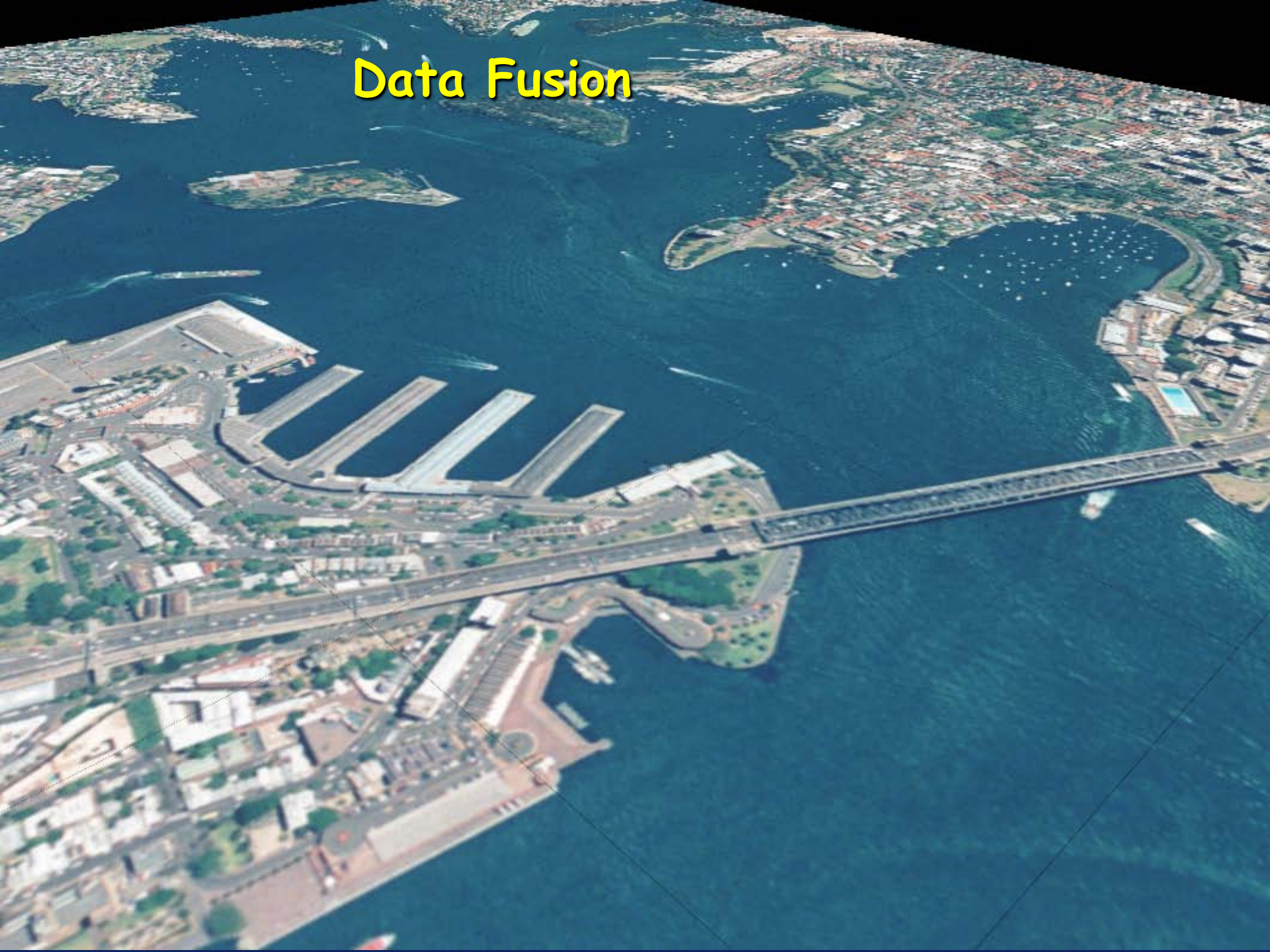

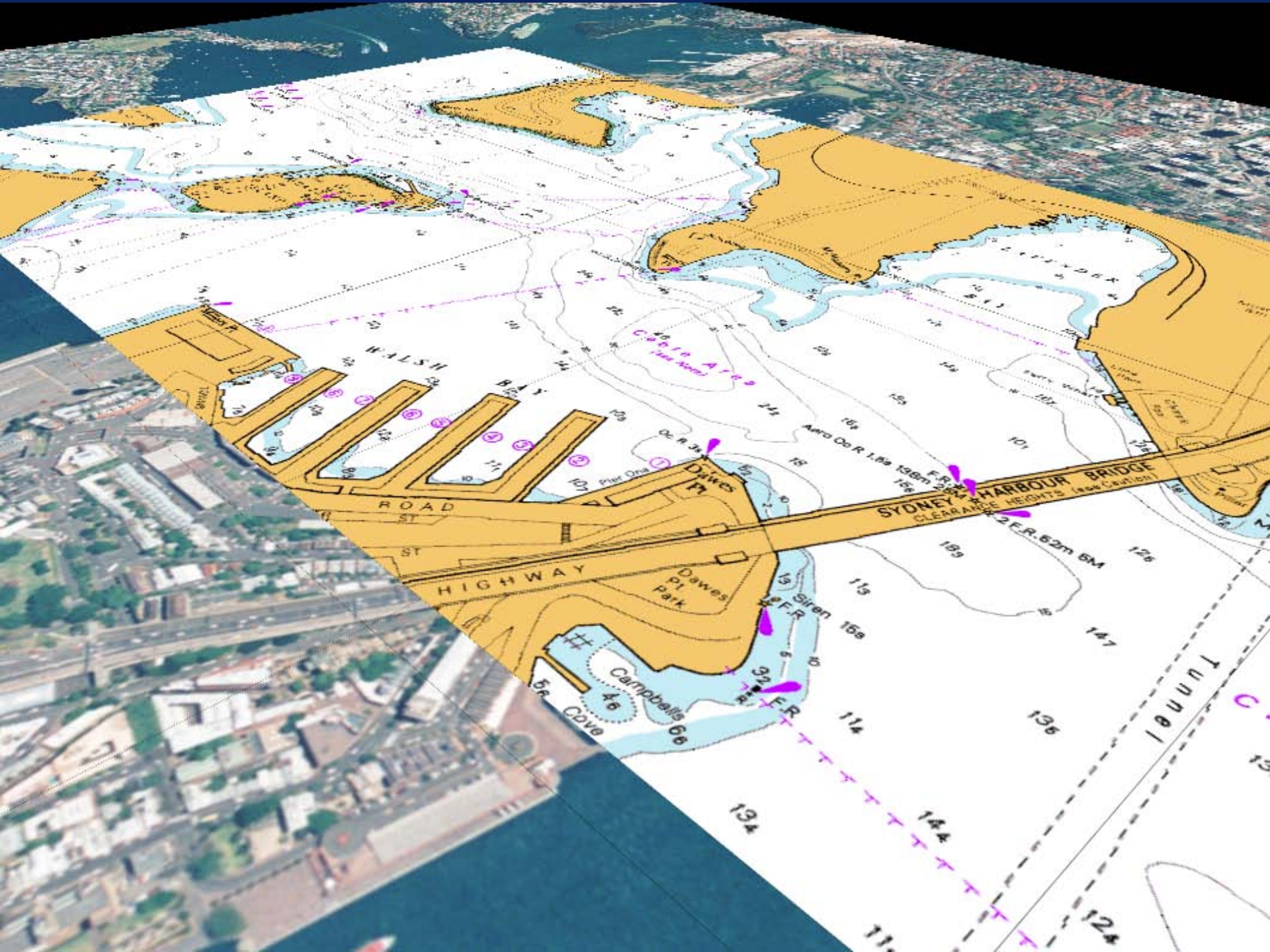

15

WALSH BAY

10

Dawes Pt

ROAD ST

ST

HIGHWAY

Dawes pt park

Campbells Cove

SYDNEY HARBOUR BRIDGE
CLEARANCE 136m 450ft
2 R. 52m 170ft

101

Aero Co R 1.0m 33ft

Siren 16m

Tunnel

134

144

124

114

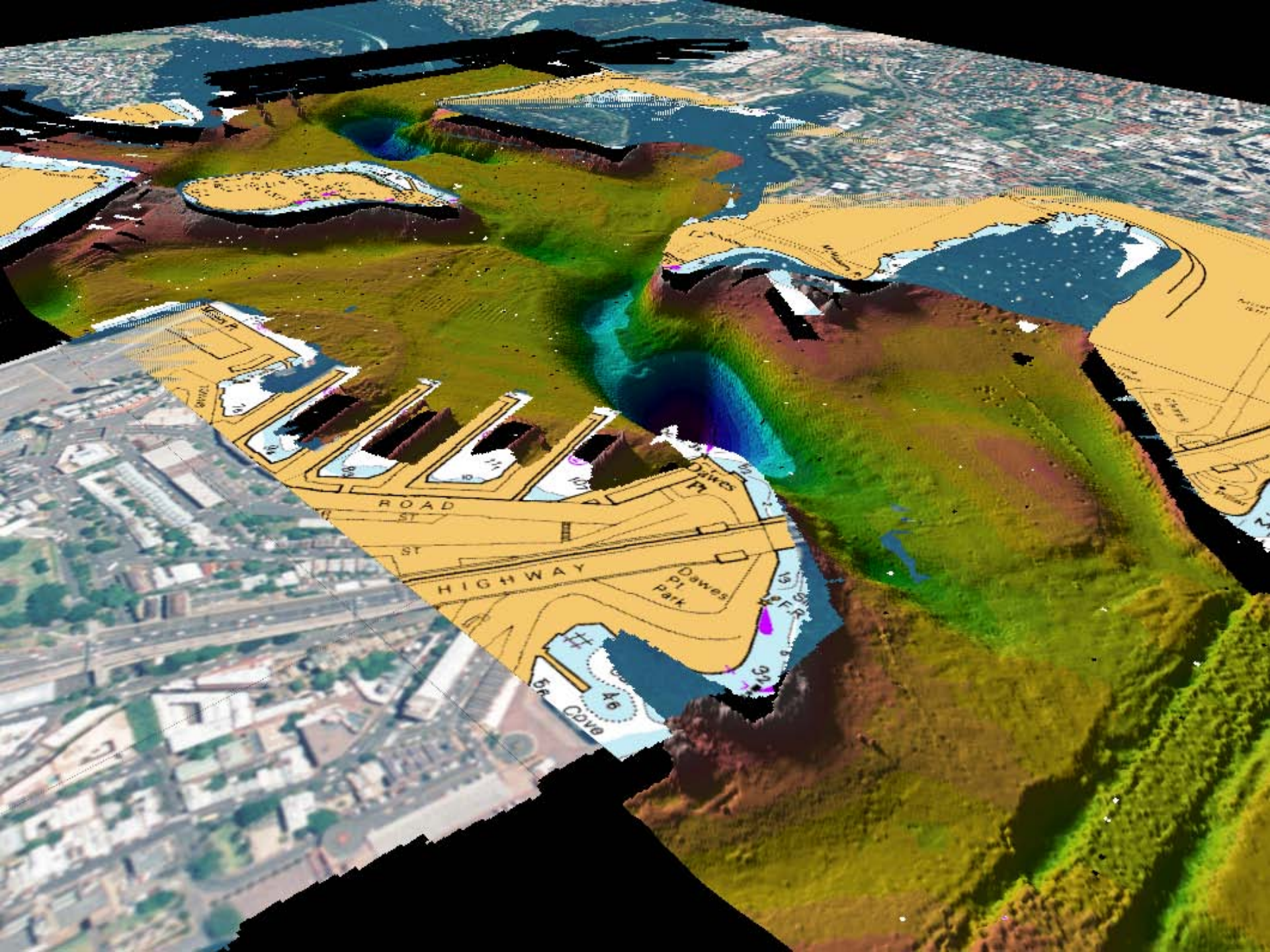

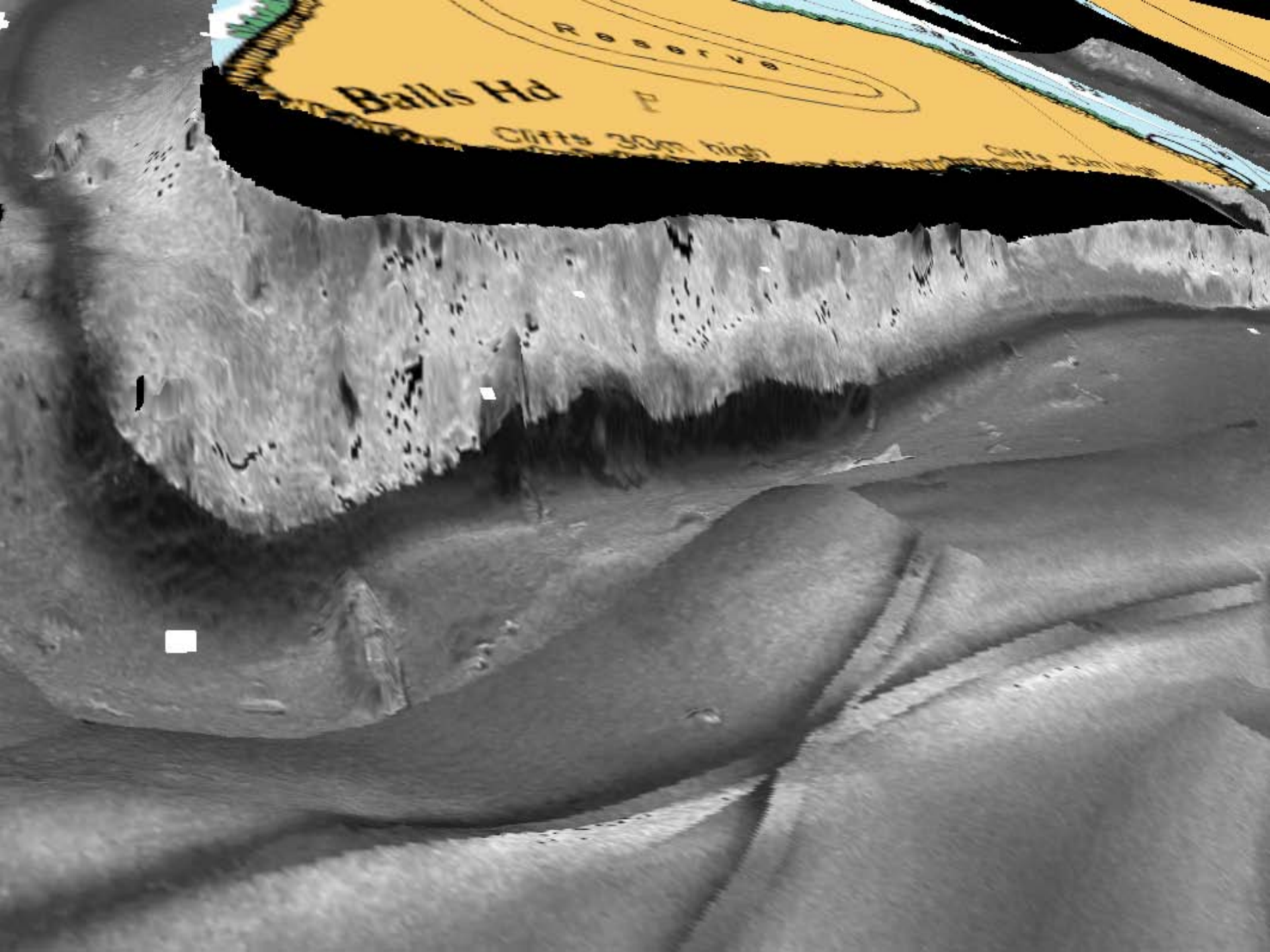

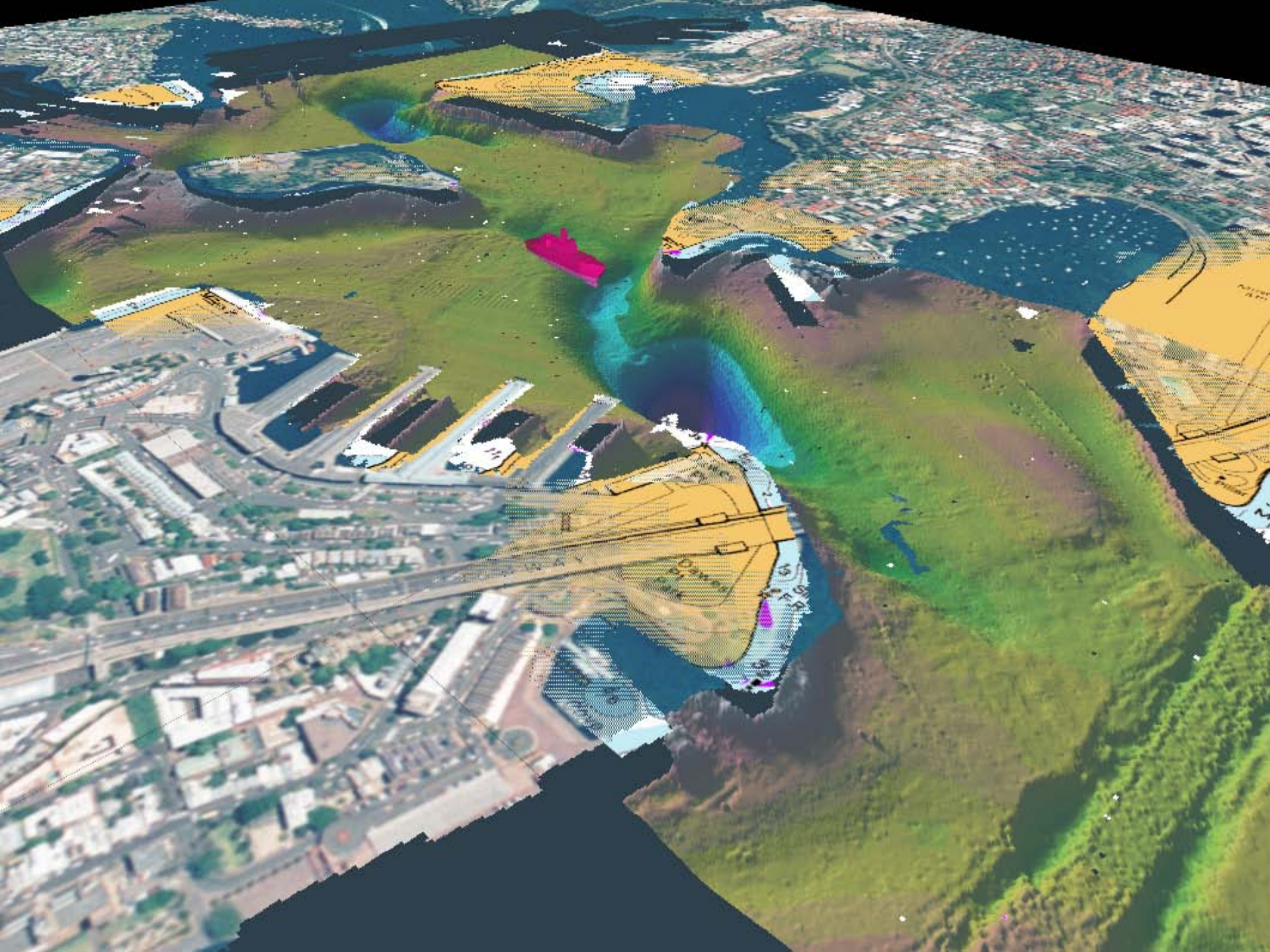

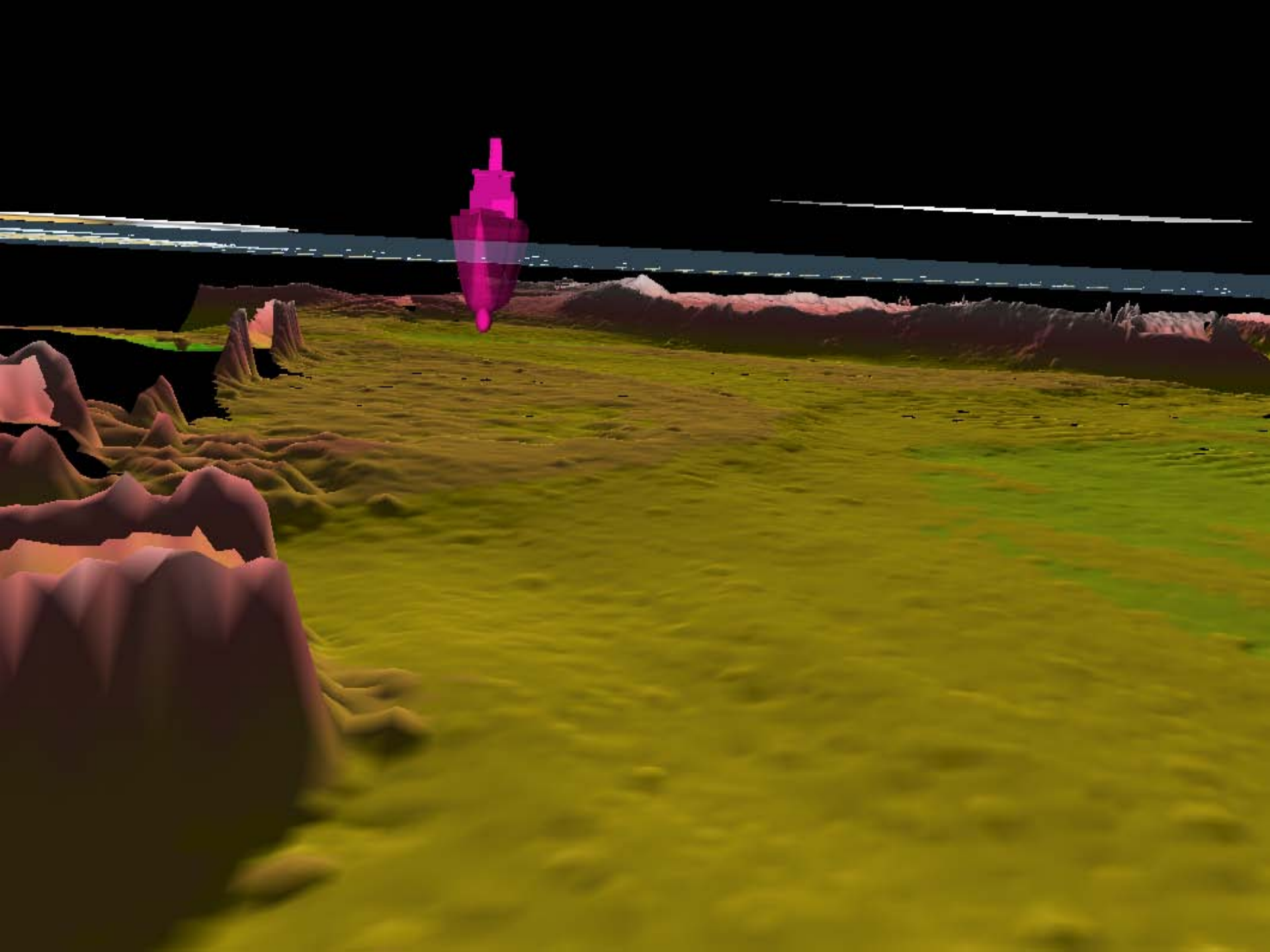

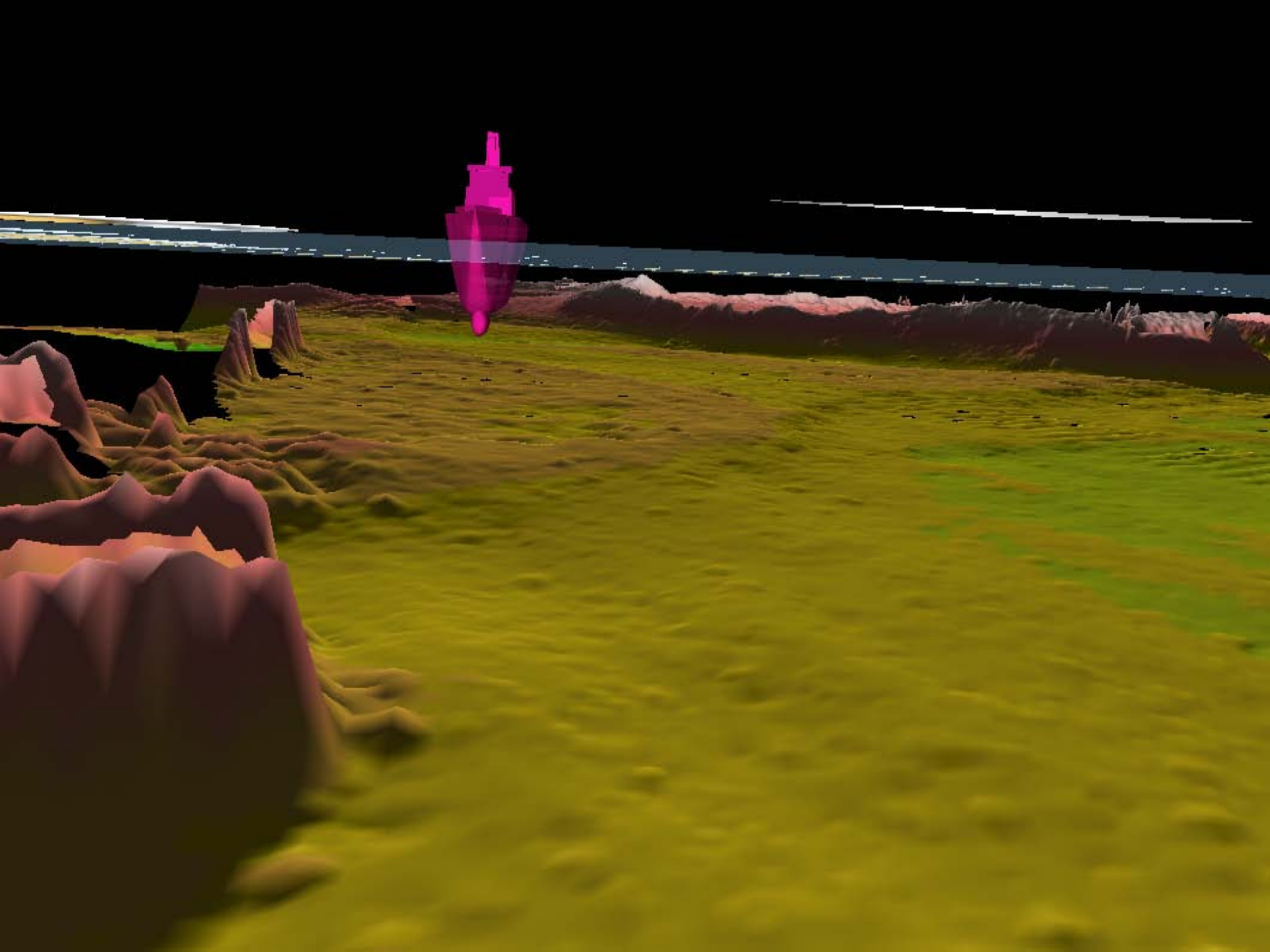

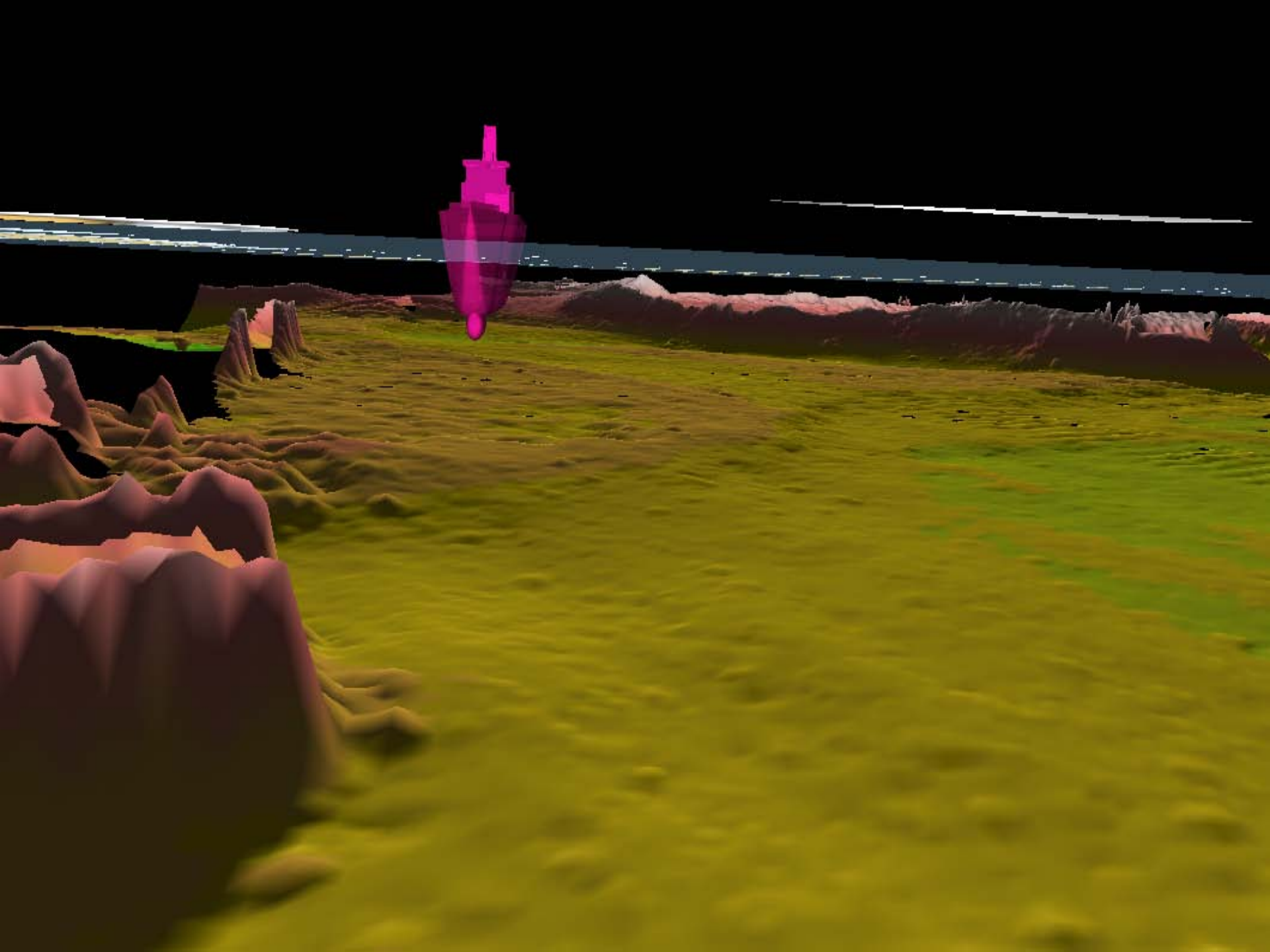

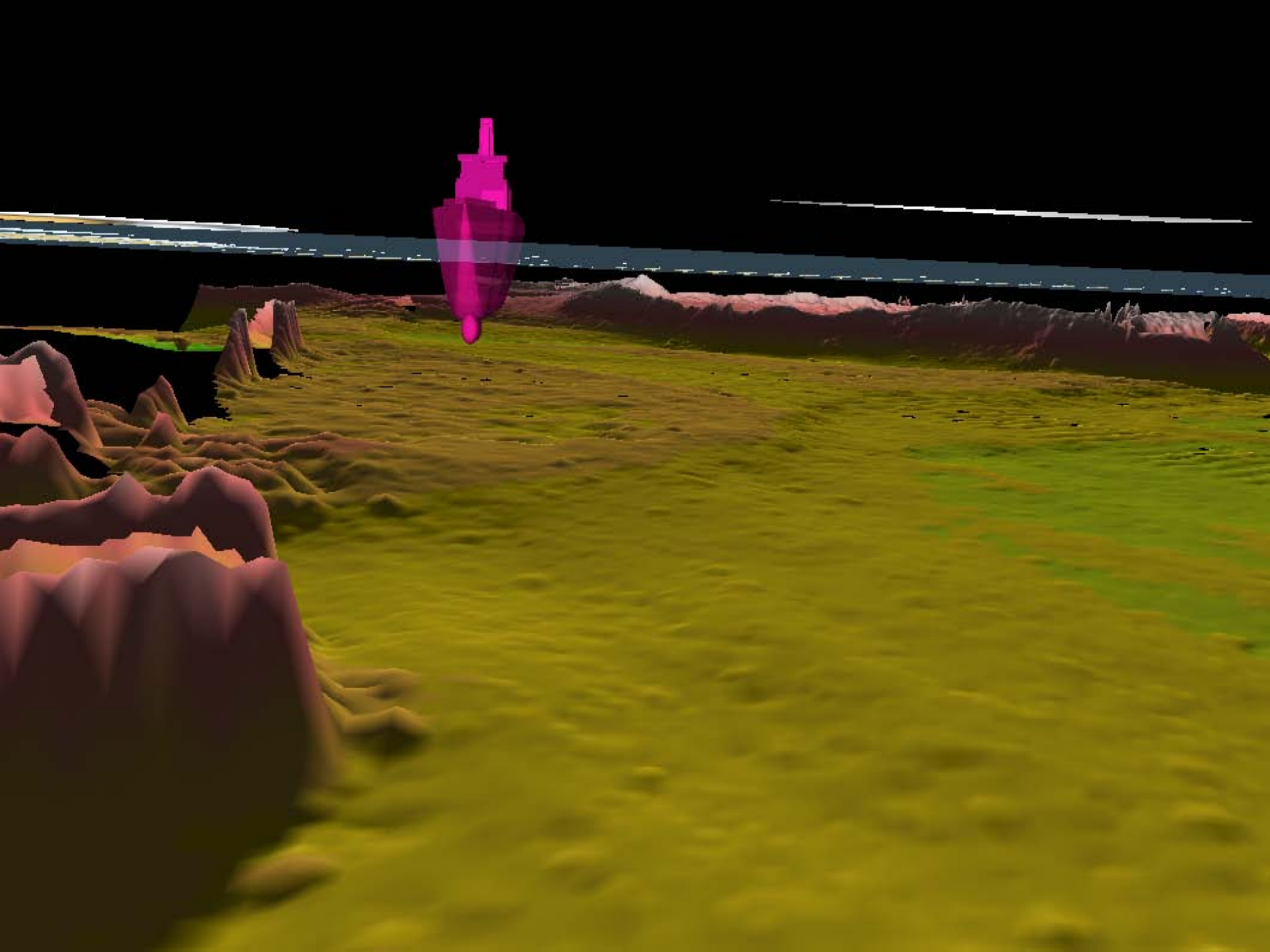

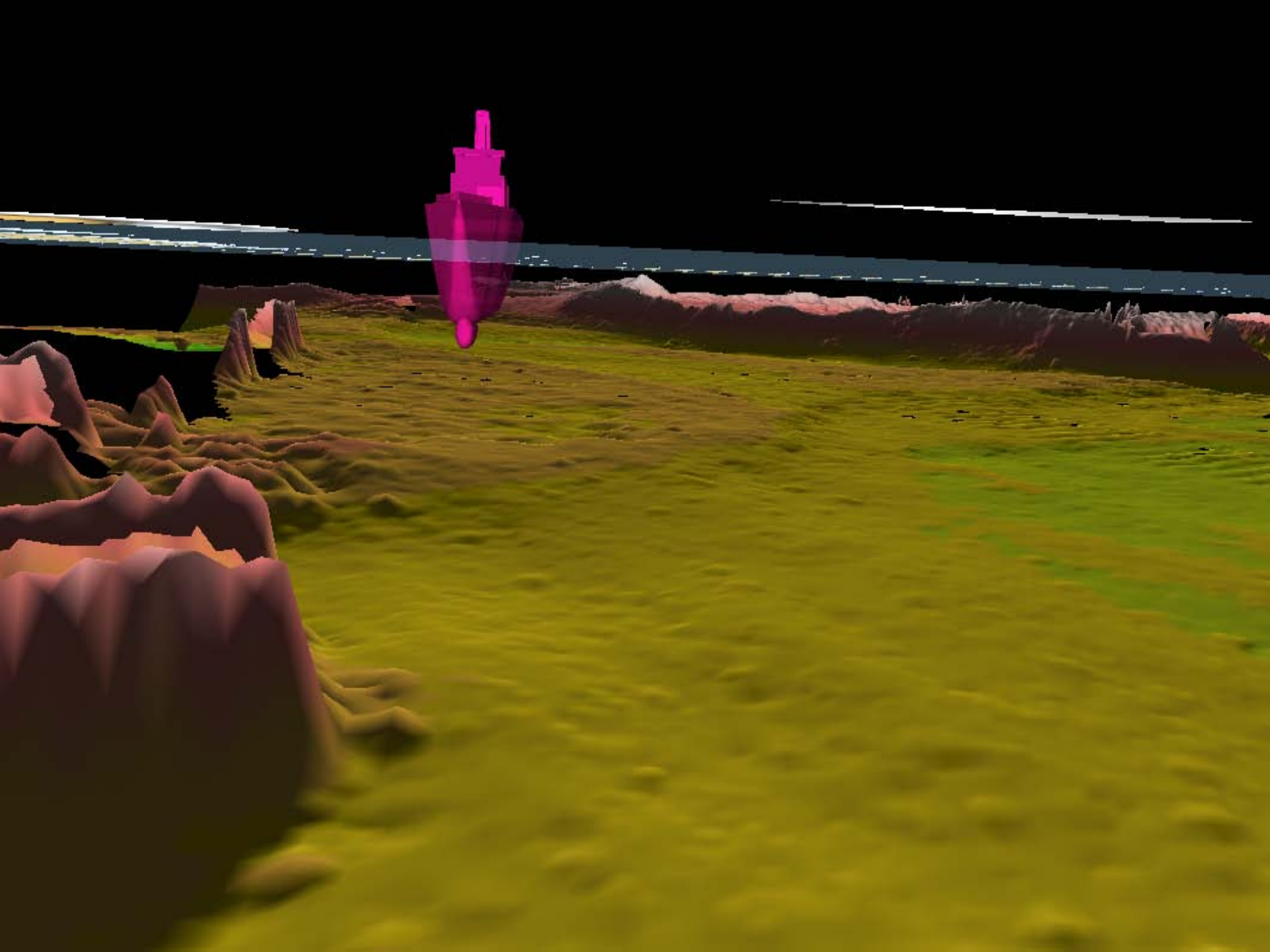

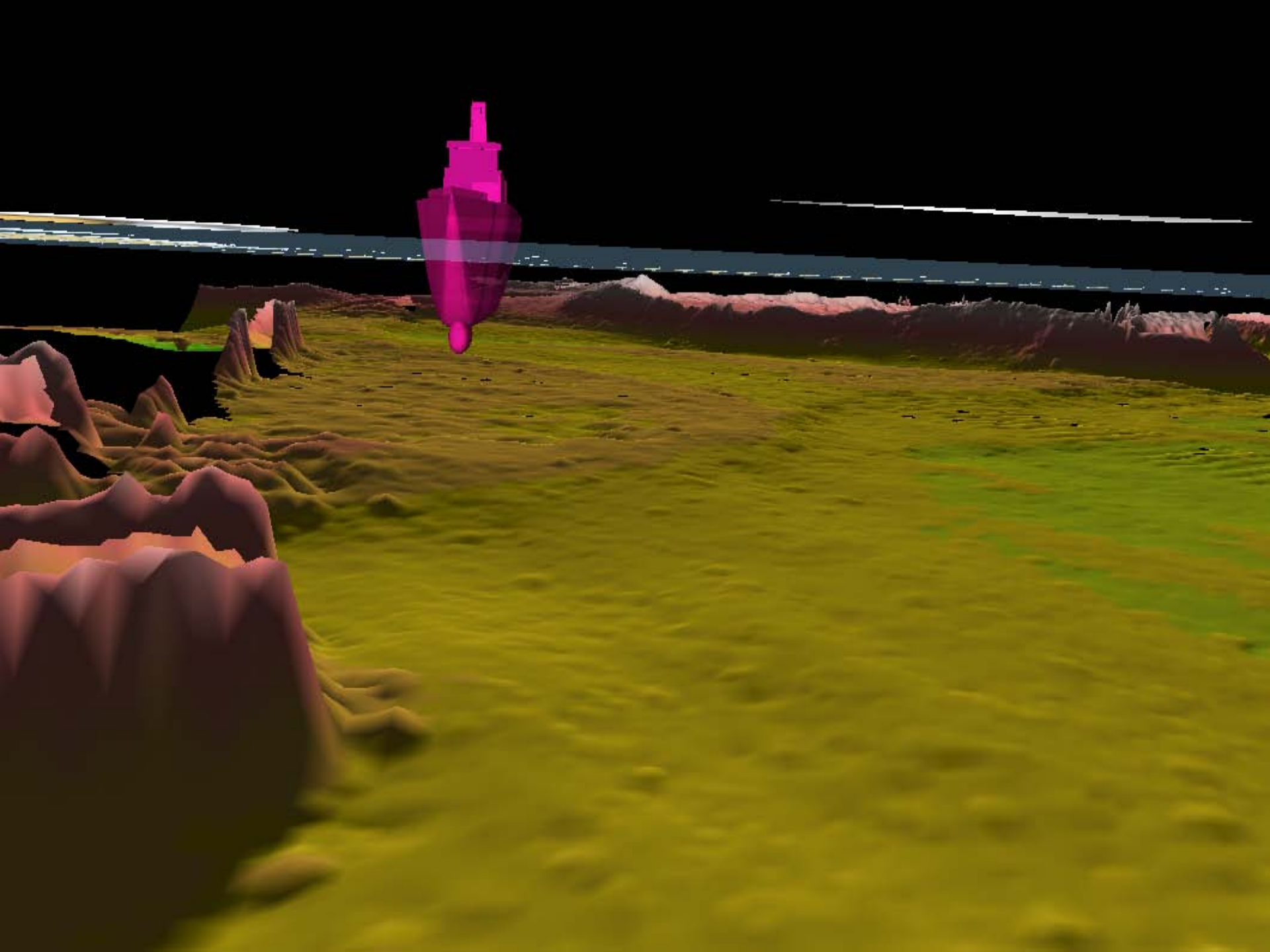

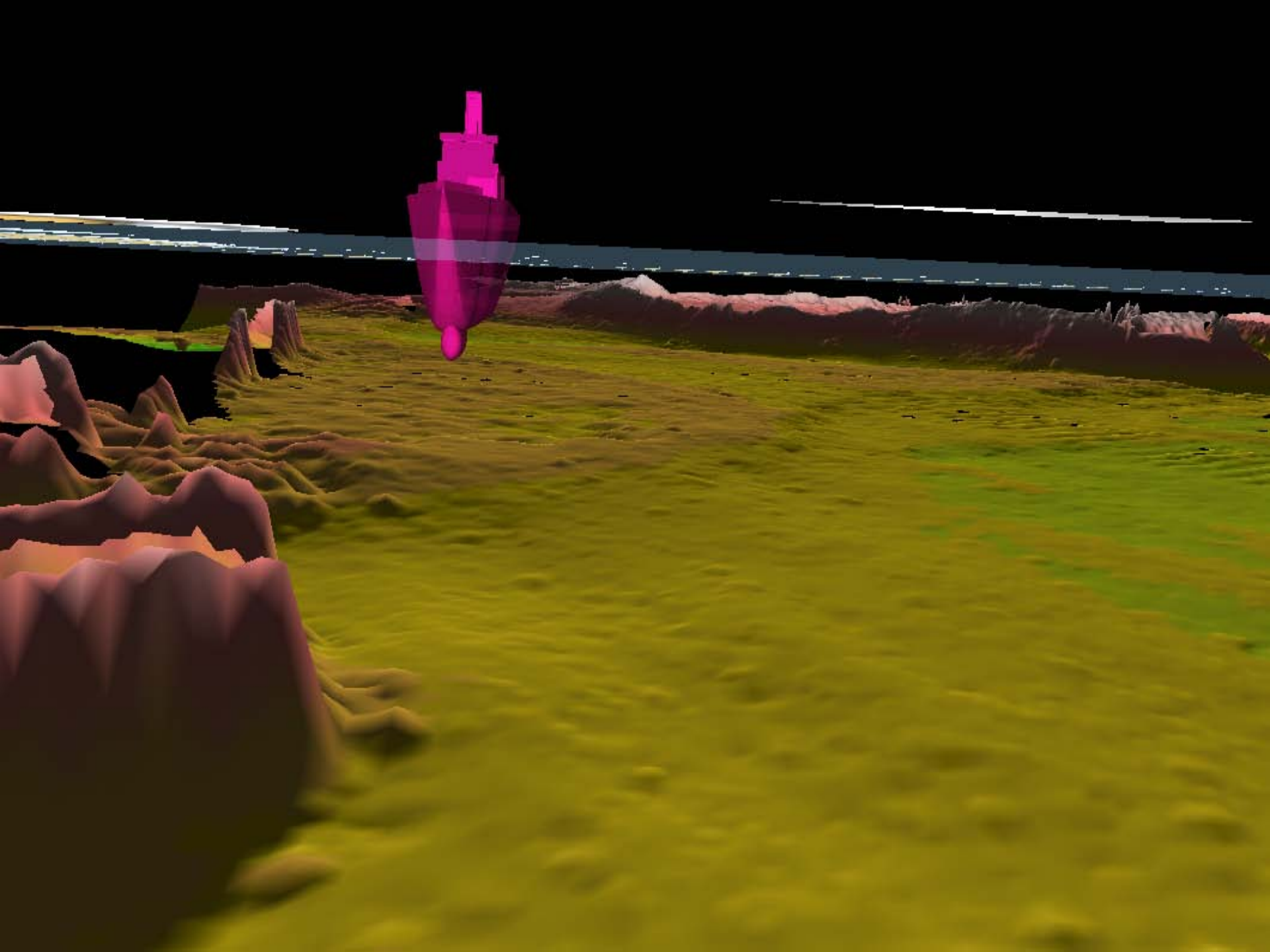

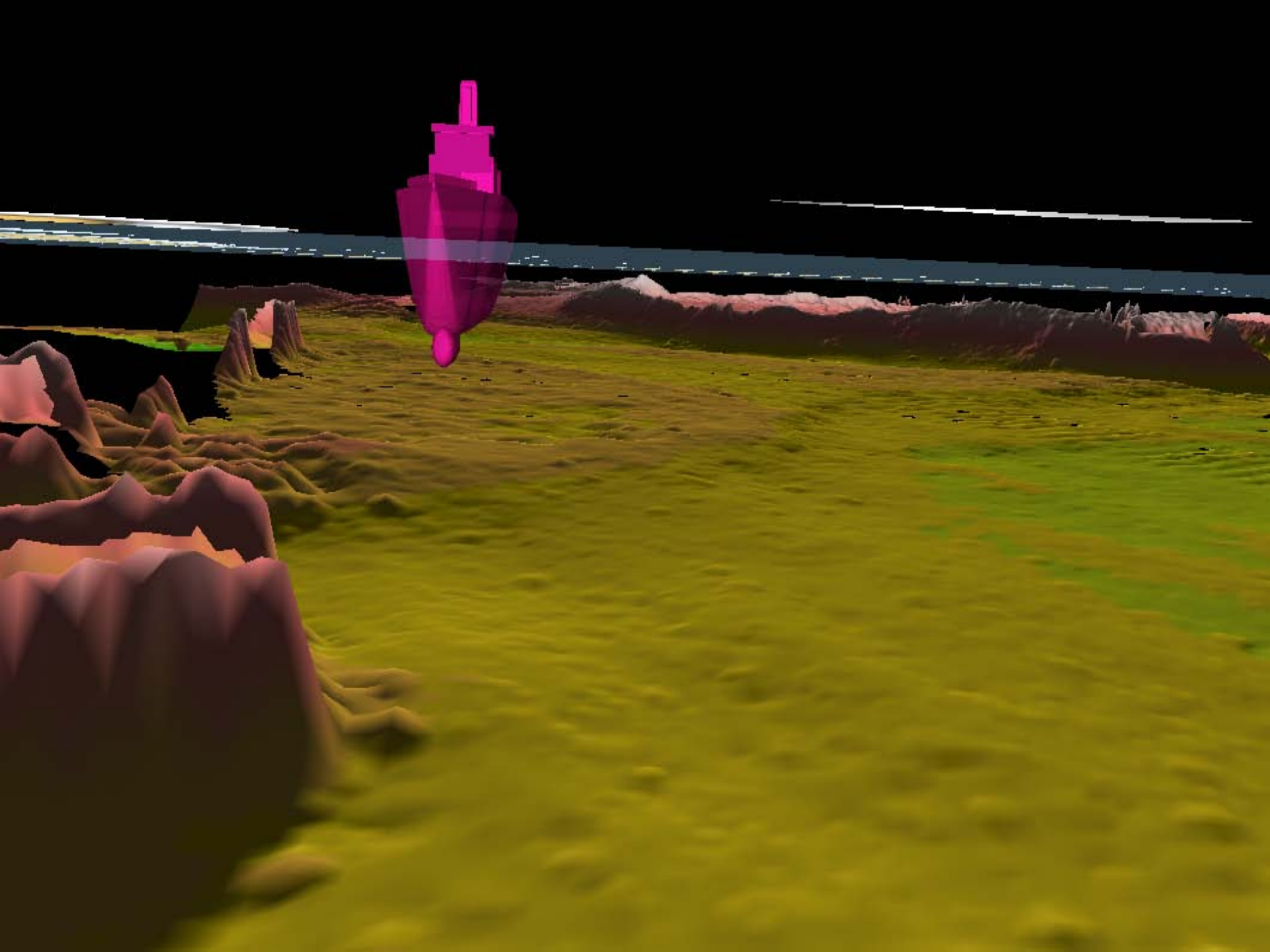

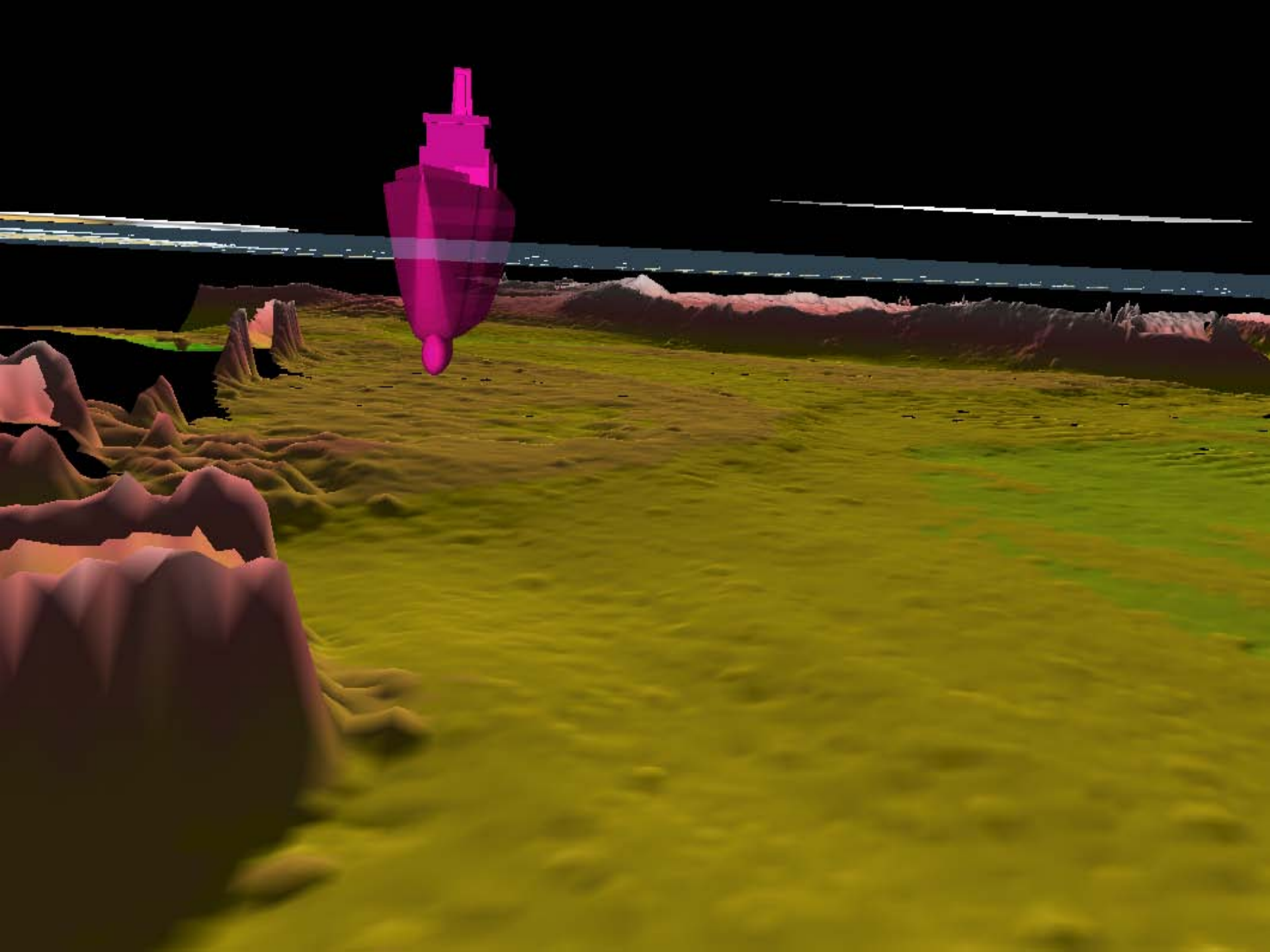

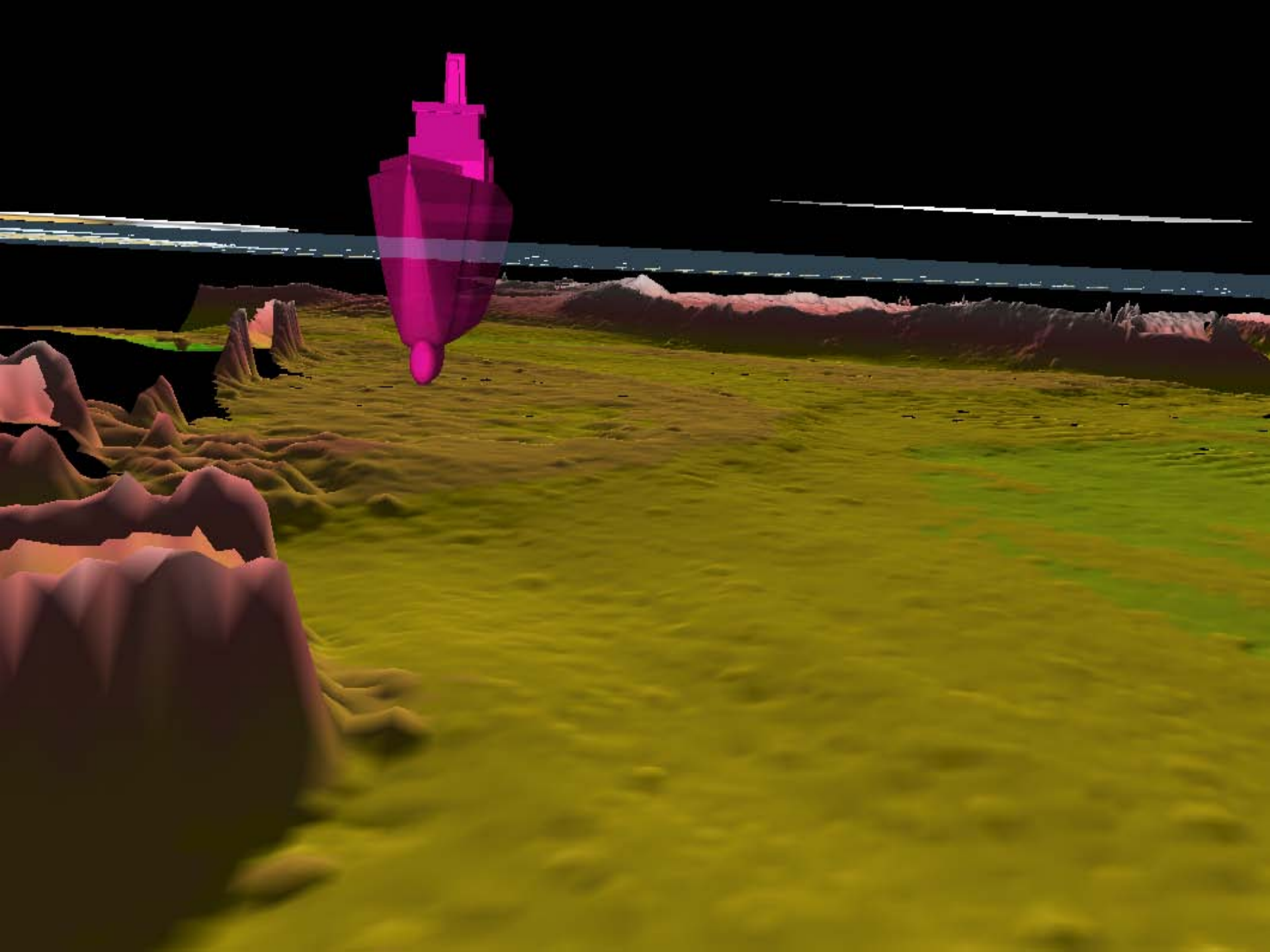

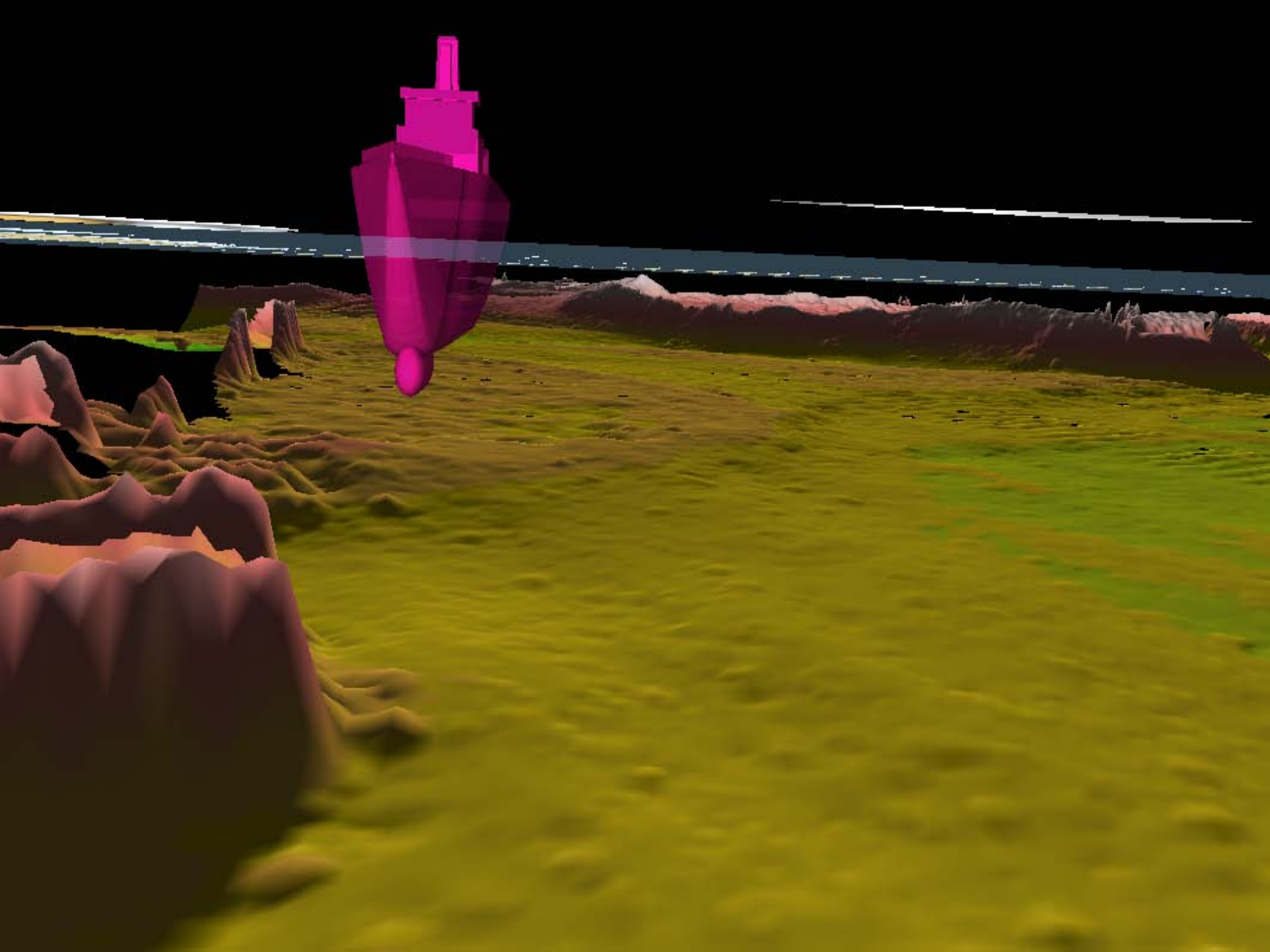

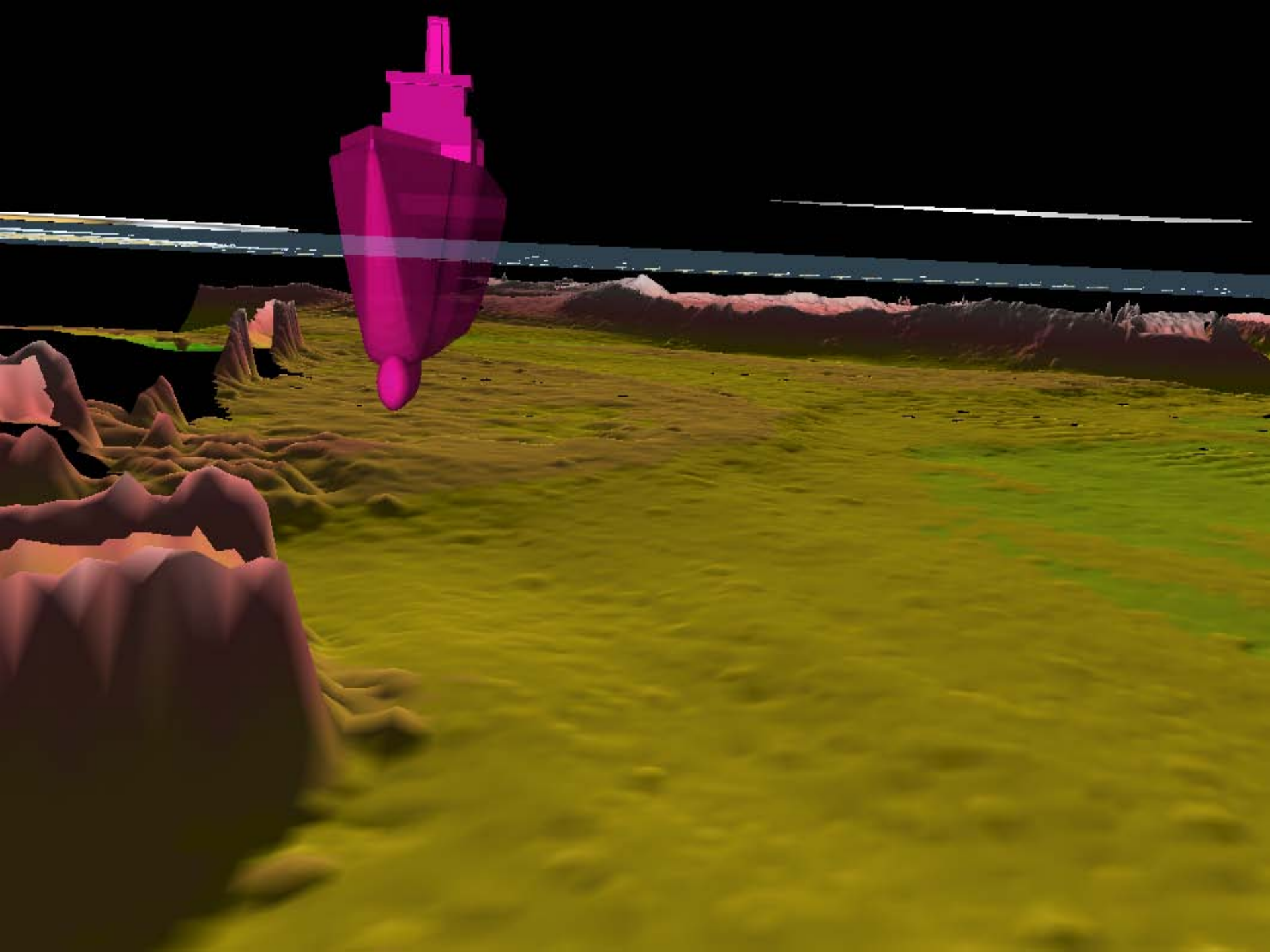

The Chart of the Future

